



Bearing Protection Handbook

Best Practices for Bearing Protection in New and Repaired Motors, Testing In-Service Motors, and Inspecting Damaged Motor Bearings



Register your motor for
the AEGIS® 2-Year Warranty
Against Bearing Fluting Damage



COMPANY INFORMATION

Electro Static Technology, An ITW Company, is a global manufacturer and inventor of AEGIS® Shaft Grounding Rings used in electric motors and other rotating equipment to safely discharge variable frequency drive (VFD) voltages to ground. AEGIS® Shaft Grounding Ring technology is installed in all ranges of motors from fractional horse power to large medium voltage motors used in virtually all commercial and industrial applications.

AEGIS® Shaft Grounding Ring technology is the only technology that combines both contact and non-contact nanogap technology to reliably protect bearings from electrical discharges that cause pitting, frosting and fluting damage. AEGIS® Ring technology uses proprietary conductive micro fibers arranged circumferentially around the motor shaft and secured in our patented AEGIS® FiberLock™ channel which protects them during operation. The following patents apply: 8199453, 8169766, 7193836, 7136271, 7528513, 7339777, and other patents pending.

Electro Static Technology is proud to be an ISO 9001:2015 company. Certificate Number: 17116

2-YEAR EXTENDED WARRANTY

Electro Static Technology (EST, AEGIS®) guarantees that AC induction motor bearings will not fail from electrical fluting damage when AEGIS® Shaft Grounding Rings have been installed with new bearings in accordance with EST's recommended best practices, as published in the AEGIS® Bearing Protection Handbook (current edition). See page 55 for more information about the 2-Year Extended Warranty, or visit www.est-aegis.com.

Register your motor at www.est-aegis.com/warranty

Units are guaranteed for one year from date of purchase against defective materials and workmanship. Replacement will be made except for defects caused by abnormal use or mishandling. All statements and technical information contained herein, or presented by the manufacturer or their representative are rendered in good faith. User must assume responsibility to determine suitability of the product for intended use. The manufacturer shall not be liable for any injury, loss or damage, direct or consequential arising out of the use, or attempt to use the product.

SAFETY



Follow all workplace safety policies and procedures applicable to electric motor repair and for all hazardous operations. Wear all applicable personal protective equipment (PPE) required by the applicable law. Employees should be informed of the relevant safety rules and employers should enforce compliance. The manufacturer shall not be liable for any injury, loss or damage, direct or consequential arising out of the use, or attempt to use the product or procedures described in this manual.

© 2020 Electro Static Technology, An ITW Company, All rights reserved.
Artwork and layout by Joanne Audet, Electro Static Technology

No part of this book may be reproduced without permission in writing from Electro Static Technology, except by a reviewer who may quote brief passages or reproduce illustrations in a review with appropriate credit; nor may any part of this book be reproduced, stored in a retrieval system, or transmitted in any form or by any means - electronic, photocopying, recording, or other-without permission in writing from Electro Static Technology.

This book is generally reviewed every year and updated. Comments and suggestions are invited. Any errors or omissions in the data should be brought to the attention of the Editor. Additions and corrections to the Handbook in print will be in the Handbook published the following printed edition and, as soon as verified, on the Electro Static Technology website.

Disclaimer - Application notes are intended as general guidance to assist with proper application of AEGIS® Shaft Grounding Rings to protect motor bearings. All statements and technical information contained in the application notes are rendered in good faith. User must assume responsibility to determine suitability of the product for its intended use.

TABLE OF CONTENTS

Introduction to Bearing Currents	4-5
About VFD Induced Shaft Voltages & Bearing Currents	6-12
Motor Grounding	13
AEGIS® Technology	14-17
AEGIS® Shaft Grounding Best Practices - Low Voltage	18-21
AEGIS® Shaft Grounding Best Practices - Medium Voltage	22-27
AEGIS® Shaft Grounding Best Practices - DC Motors	28-29
AEGIS® Installation and Shaft Preparation	30-33
AEGIS® Shaft Voltage Testing	34-43
Selecting the Correct Size Ring	44
AEGIS® Shaft Grounding Ring Parts List	45-53
Engineering Specification	54
AEGIS® 2-Year Extended Warranty Description	55



BEARING CURRENTS

MOTOR GROUNDING

AEGIS® TECHNOLOGY

LOW VOLTAGE MOTORS

MED VOLTAGE MOTORS

DC MOTORS

INSTALL SHAFT PREP

SHAFT VOLTAGE TESTING

SELECT CORRECT SIZE

PARTS LIST

ENGINEERING SPEC



ANSI/EASA Standard AR100-2015, Section 2, Mechanical Repair: 2.2 Bearings
“Bearings should be inspected for failure modes such as spalling, contamination, fretting, fluting, and scoring.”

Operation of Electrical Motors by Variable Frequency Drives:

AC Motors operated by variable frequency drives (VFD) use pulse width modulation (PWM) to control the speed of the motor. This means that there are common mode voltages which are capacitively induced onto the shaft of the motor and can discharge in the motor's bearings causing electrical discharge machining (EDM) pitting, frosting and fluting damage which results in unplanned downtime and repair costs. In addition, larger motors over 75 kW and medium voltage motors may also have high frequency circulating currents which can also cause EDM pitting, frosting and fluting damage. DC Motors on drives may also have capacitively induced shaft voltage which can discharge in the motor's bearings and in addition, motors over 7,5 kW may also have circulating currents.

Bearing Protection Specified for New Motors and Motor Repair:

It is essential that motors operated by VFDs or DC drives are configured for bearing protection from both types of current sources. Installing AEGIS® Shaft Grounding Rings provide a proven and reliable ground path to discharge the capacitively induced voltages safely away from the motor's bearings to ground. Motors with circulating currents should also have shaft or housing insulation or one insulated bearing installed on opposite end from the AEGIS® Shaft Grounding Ring to stop the high frequency circulating current path. This approach is the recommended best practice to make inverter driven motors **“True Inverter Duty”** by protecting the most critical mechanical component of the motor – the motor's bearings.

Bearing Inspection:

Whenever a VFD driven motor fails, the motor's bearings should be removed, cut, and inspected for evidence of EDM discharges. Sometimes it is obvious because the damage is visibly apparent with a “washboard” fluting pattern on the inner or outer bearing race. The ANSI/EASA AR100-2015 recommends this practice for all electric motor repairs. Preventing this failure mode from the start creates a common sense methodology for increasing the reliability of all VFD driven motor systems.

Shaft Voltage Testing:

The NEMA MG1 Part 31.4.4.3 identifies capacitive shaft voltages of 10 to 40 volts peak (or 20 to 80 volts peak-to-peak) as a level which could cause electrical discharges in a motor's bearings. Testing for shaft voltages is the best way to confirm the need for AEGIS® Shaft Grounding Rings on VFD driven electric motors to prevent EDM bearing damage and to ensure uptime and reliability. The AEGIS® Shaft Voltage Tester™ Digital Oscilloscope is specifically designed to measure and record shaft voltages.

Shaft voltage testing is best accomplished as early as possible in the operation cycle of the VFD/Motor system and whenever a new motor is installed, after a motor repair or bearing replacement is done, and upon commissioning of newly constructed buildings or installation of new production equipment.

Proper Earth Grounding of VFD-Driven Motor Systems:

Proper high-frequency (HF) grounding of VFD-driven motor systems is vital to prevent earth-level discontinuities between system components. It is especially critical in applications involving a motor and coupled equipment that are not mounted to a common baseplate. In such cases, effective HF grounding of all system components is necessary to equalize the electric potential between equipment frames and to prevent ground loops between the motor and coupled equipment. Widely recognized as the most efficient path to ground for high frequency currents, high-frequency grounding straps (such as AEGIS® HFGS) are recommended by major motor and drive manufacturers.



EDM Electrical Discharge Machining

Because of the high-speed switching frequencies in Pulse Width Modulation (PWM) inverters, variable frequency drives induce capacitively coupled shaft voltages in the electric motors they control. The high frequency switching speed of insulated-gate bipolar transistors (IGBT) used in these drives produce common mode voltages on the motor's shaft during normal operation through parasitic capacitance between the stator and rotor. These voltages, which can register 10-40 volts peak, are easily measured by touching an AEGIS® Shaft Voltage Probe™ to the motor's shaft while the motor is running. The AEGIS-OSC-9100 Shaft Voltage Tester™, a 100 MHz Digital Oscilloscope, allows the voltages to be viewed and recorded for analysis.

Reference: NEMA MG1 Section 31.4.4.3

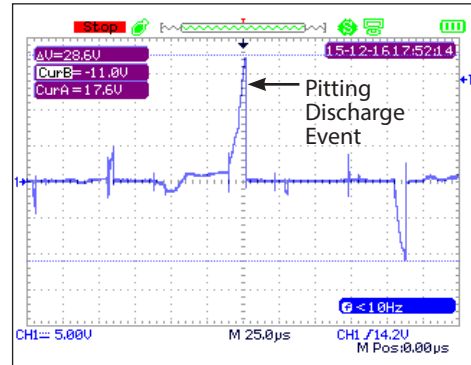

Once these voltages reach a level sufficient to overcome the dielectric properties of the bearing grease, they arc through the motor's bearings, discharging along the path of least resistance to the motor's housing. During virtually every VFD switching cycle, induced shaft voltage discharges from the motor's shaft to the frame via the bearings, leaving a small fusion crater (fret) in the bearing race. When this event happens, temperatures are hot enough to melt the 52100 vacuum degassed bearing steel and severely damage or burn the bearing lubrication.

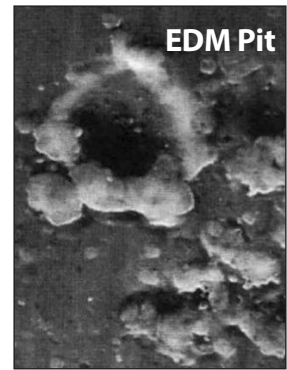
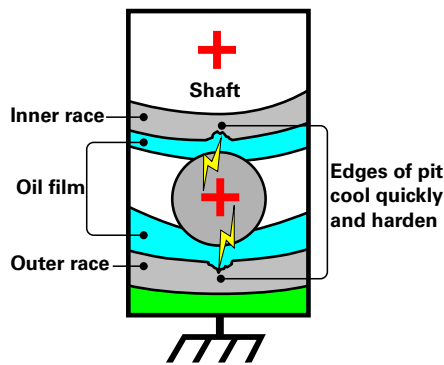

These discharges are so frequent (potentially millions per hour) that before long the entire bearing race surface becomes damaged with countless pits known as frosting. A phenomenon known as fluting may occur as well, producing washboard-like ridges across the frosted bearing race. Fluting causes audible noise and vibration and is an indication of a catastrophic failure mode. Regardless of the type of rolling element or raceway damage that occurs, the resulting motor failure often costs thousands of dollars in downtime and equipment failure related repair or replacement costs.

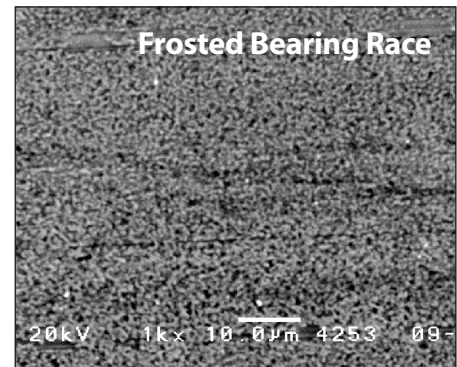

Failure rates vary widely depending on many factors, but evidence suggests that a significant portion of failures occur in only 3 to 12 months after system startup. All AC and DC motors operated by electronic drives or inverters have the potential of developing this failure in their bearings regardless of motor frame size or horsepower.

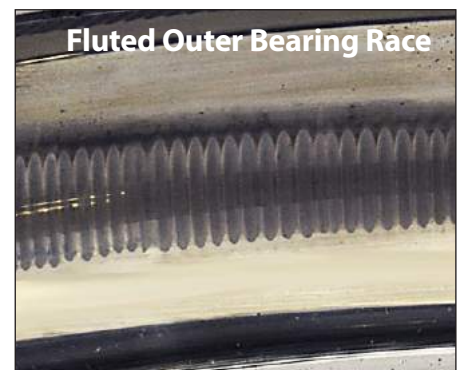

Bearing Inspection



Cutting and inspecting every bearing in motors that come in for repair, especially motors operated on variable frequency drives, will often provide vital information to make the best repair recommendation and thus improve the machine's overall lifetime performance.

Report template available at: www.est-aegis.com/bearing



1. **Inspect the outside and the inside of both bearings** and retain a sample of the lubricant for analysis. Look for:
 - a. Contamination
 - b. Signs of excessive heat
 - c. Hardening of grease
 - d. Abnormal coloration (blackened grease)
 - e. Excess grease and oil escaping the bearing



2. **Cut the outer race** into halves. Remove seals or shields prior to cutting.



Follow established safety precautions and use personal protective equipment including eye protection, hearing protection, face shield, gloves and protective clothing.



3. **Inspect the grease** and any contamination in the bearing.
 - a. **Burnt Grease:** Continuous electrical arcing in the motor bearings will often rapidly deteriorate the lubricating capability of the grease and cause bearing race damage. When an arc occurs, the oil component of the grease is heated beyond its temperature capacity.
 - b. **Contamination:** In addition to the burnt grease, the arcing causes small metal particles to loosen from the bearing races/balls which are distributed in the grease. These particles are abrasive and will cause the bearing to prematurely wear.



Burnt bearing grease is blackened and oftentimes contaminated with metal particles.

New bearing grease is available in many colors. Blue grease (as shown) is Polyrex EM. It is commonly found in electric motor bearings.



4. Clean the bearing's components using a degreaser or solvent.



Follow all safety precautions.

5. Inspect for evidence of Electrical Discharge Machining (EDM):

EDM damage is millions of microscopic electrical pits that are created when current discharges through the motor's bearings. The electrical voltage overcomes the dielectric of the bearing lubrication and instantaneously arcs through the inner race, through the rolling elements and to the outer race. The individual pits are usually between 5 and 10 micron diameter.



6. Frosting: This will appear to be a grey discolored line around all or part of the bearing race and may be evident in both the inner and outer race. The discoloration may be caused by mechanical wear or by EDM. Examination under a microscope may be required to determine if the line is EDM or of a mechanical nature. If the motor was operated on a VFD with no bearing protection there is a high likelihood that the frosting is from EDM.

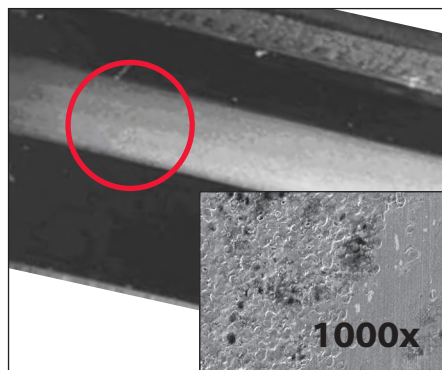

7. Fluting Damage: Identified by a distinctive washboard pattern. Fluting can be identified with the naked eye or with 10x magnification. Fluting is sometimes confused with mechanical bearing damage such as brinelling/false binelling, so care should be taken to correctly assign electrical fluting damage to the pattern observed.



In addition to using this manual, please refer to other bearing failure analysis experts in order to determine the root cause of failure.

Install new AEGIS® Ring whenever bearings are replaced on an inverter-driven motor.

BEARING CURRENTS

MOTOR GROUNDING

AEGIS® TECHNOLOGY

LOW VOLTAGE MOTORS

MED VOLTAGE MOTORS

DC MOTORS

INSTALL SHAFT PREP

SHAFT VOLTAGE TESTING

SELECT CORRECT SIZE

PARTS LIST

ENGINEERING SPEC



Three Sources of Bearing Current:

There are three sources of bearing currents discussed in this handbook, two of which, Capacitive EDM Current and High Frequency Circulating Current are sourced by the VFD. The third type, which we label 50 Hz Circulating Current, is mainly in large AC motors that are operated by line voltages at 50 Hz.

- 1. Capacitive EDM Current (from VFD):** Capacitive induced voltage from the pulse width switching waveform produced by the variable frequency drive (VFD). This voltage is coupled to the motor's shaft through parasitic capacitance and can discharge in the motor's bearings or in the bearings of attached equipment causing electrical discharge machining (EDM).
- 2. High Frequency Circulating Current (from VFD):** High frequency circulating currents may flow due to a high-frequency flux produced by common-mode currents. High frequency inductive circulating currents from VFDs are in the kHz or MHz range and may be present in motors over 75 kW. Generally the larger the motor the greater the effects of the high frequency circulating currents.
- 3. 50 Hz Circulating Current (from line voltage):** 50 Hz Sine wave voltage sources in large machines can cause *extremely low frequency circulating currents* because of the motor's asymmetrical design and magnetic asymmetries.

Total Qualitative Bearing Currents

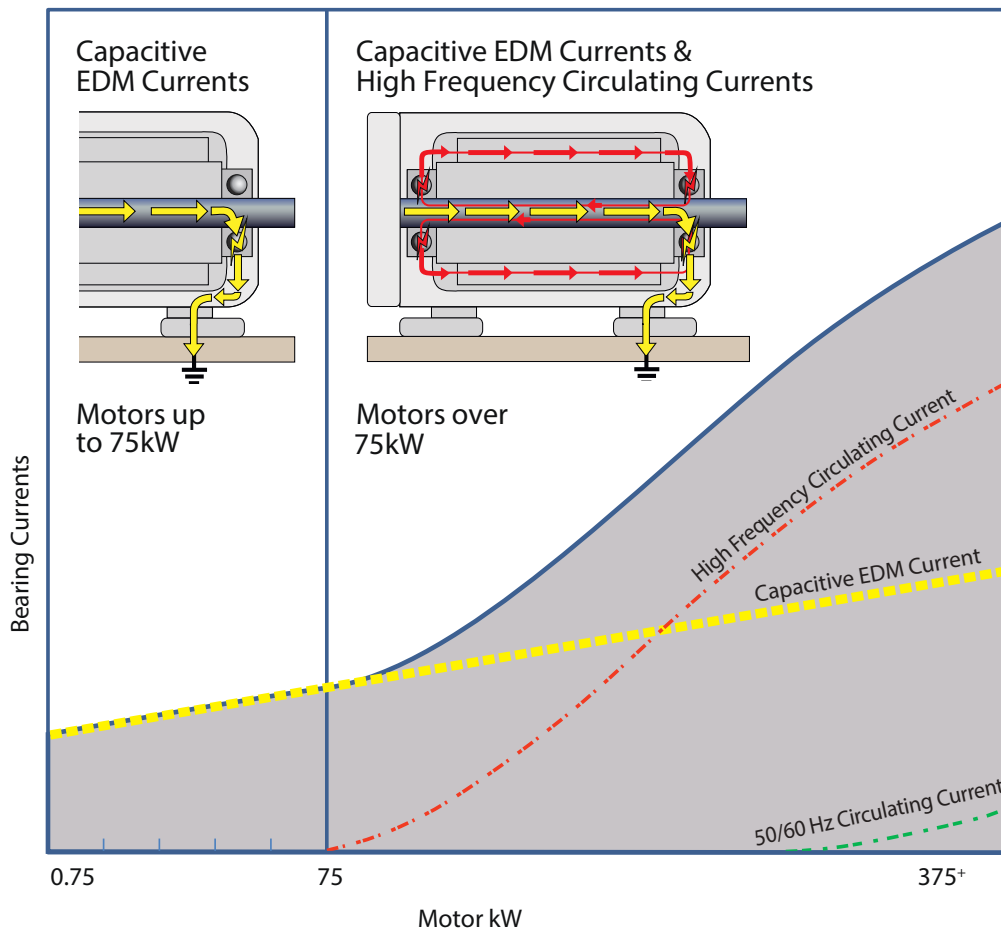

Patented Technology

Electric Motors Operating on Line Voltage

Balanced voltage condition



- Electric induction motors are designed for operation on 3 phase sine wave power - 50 Hz.
- The input power is balanced in frequency, phase (120 degree phase shift) and in amplitude.
- Common mode voltage - the sum of the 3 phases always equal zero volts when properly balanced.

Note: Bearing protection generally not needed except for large frame motors.

Electric Motors Operated by Variable Frequency Drives (VFD)

Unbalanced voltage condition

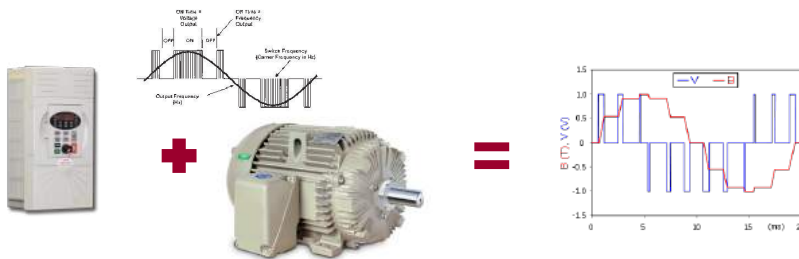

- When operated by VFD, the power to the motor is a series of positive and negative pulses instead of a smooth sine wave.
- The input voltage is never balanced because the voltage is either 0 volts, positive, or negative with rapid switching between pulses in all three phases.
- The common mode voltage is usually a “square wave” or “6 step” voltage wave form.

! Bearing protection needed to mitigate electrical discharge machining (EDM) damage in bearings.



Capacitive EDM Current

An Electric Motor works like a Capacitor

- The pulses to the motor from the VFD create a capacitively coupled common mode voltage on the motor's shaft.
- Creates electrical bearing discharge currents.
- Voltages are measurable with an AEGIS® Shaft Voltage Tester™ Digital Oscilloscope (AEGIS-OSC-9100) and AEGIS® SVP Shaft Voltage Probe™ Tip.



AEGIS-OSC-9100

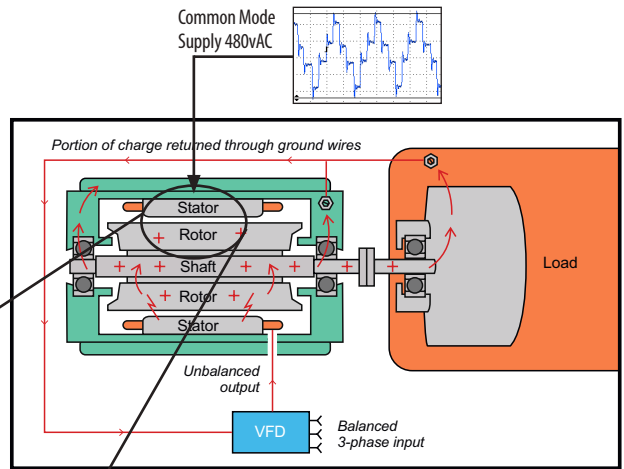
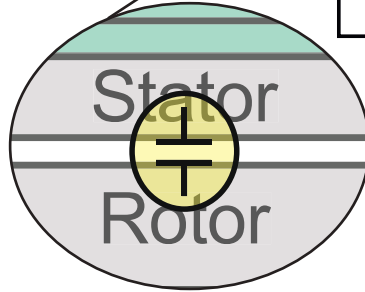

Voltage Arcs through the Bearing

- Voltages arc through the bearings, and electrical discharge machining (EDM) creates thousands of pits in the bearing's race.
- Bearings degrade, resulting in increased friction and noise
- Eventually, the rolling elements can cause fluting damage to the bearing races
- Bearing lubrication/grease deteriorates, is burnt and fails
- Potential for costly unplanned downtime

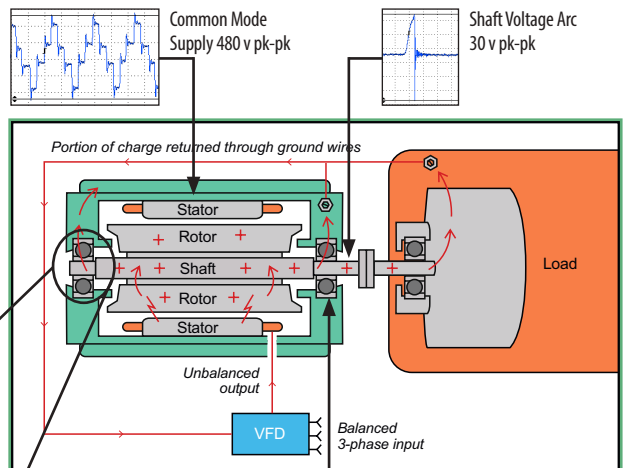
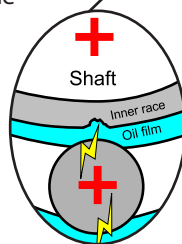

Burnt Grease

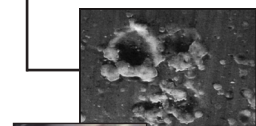

EDM Pits



Fluting



Patented Technology

High Frequency Circulating Currents on VFD Driven Motors

Induced by the magnetic flux imbalance around the motor shaft from the stator windings, these currents circulate through the motor bearings. High Frequency Circulating Currents can be a problem in large AC motors over 75 kW and DC motors over 7,5 kW.

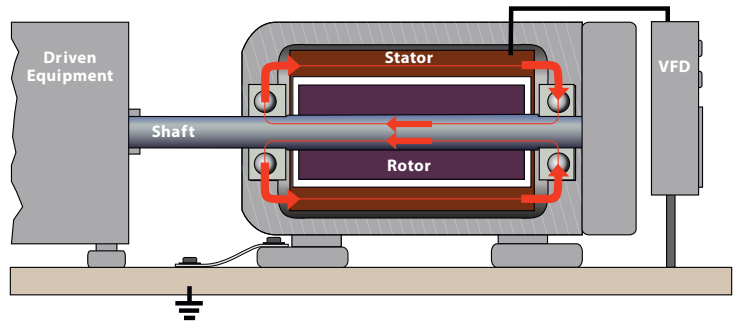

Along with the high frequency circulating currents you will also have the capacitive EDM current which can travel down the shaft to attached equipment and cause electrical discharge machining (EDM) in the equipment's bearings or gearing. Therefore it is important when considering high frequency circulating currents to also mitigate capacitive EDM current with the AEGIS® Shaft Grounding Ring to divert the voltages away from the drive end motor bearing and/or the attached equipment to ground.

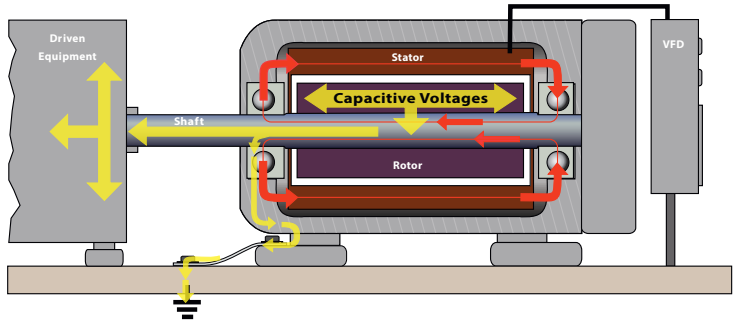

Best Practice to Protect from Both Capacitive EDM Current and High Frequency Circulating Current

The recommended best practice is to stop the high frequency circulating currents by isolating or insulating the non-drive end of the motor (NDE) and to install an AEGIS® Shaft Grounding Ring on the drive end (DE), on the opposite side from the insulation, for capacitive EDM current. This practice will protect both the motor's DE bearing and the attached equipment.

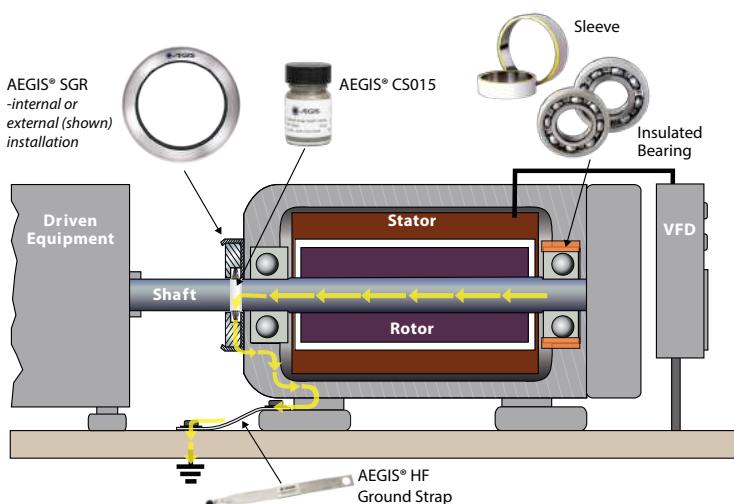

BEARING CURRENTS

MOTOR GROUNDING

AEGIS® TECHNOLOGY

LOW VOLTAGE MOTORS

MED VOLTAGE MOTORS

DC MOTORS

INSTALL SHAFT PREP

SHAFT VOLTAGE TESTING

SELECT CORRECT SIZE

PARTS LIST

ENGINEERING SPEC



50 Hz Circulating Current - Low Frequency Circulating Currents from 50 Hz Line Voltage in IEC Motors over 315 Frame

Sinusoidal voltage sources can cause low frequency circulating currents in large machines due to the motor's asymmetrical design. 50 Hz operation can result in circulating currents due to motor magnetic asymmetries.

- a. Usually present in very large machines only.
- b. Circulate through the motor bearings, shaft to frame.

Best Practice: Interrupting the circulating current is the best approach to mitigating potential bearing damage.

Ref: NEMA MG1 Part 31.4.4.3

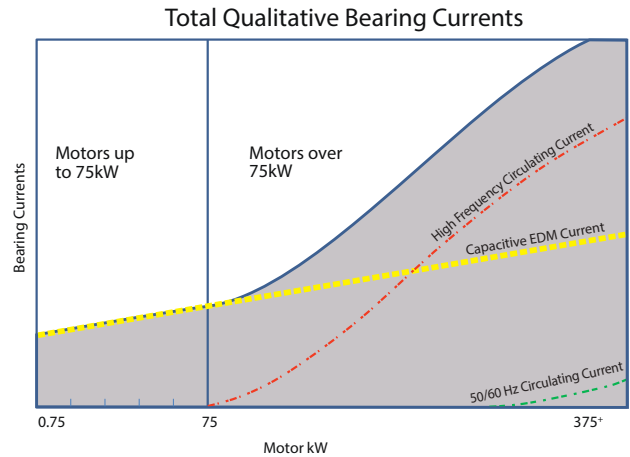

Grounding Path

The AEGIS® Ring conducts harmful shaft voltages away from the bearings to ground. Voltage travels from the shaft, through the conductive microfibers, through the housing of the ring, through the hardware (or conductive epoxy) used to attach the ring to the motor, to ground.

The AEGIS® HFGS (High-Frequency Ground Strap) is a braided cable used to lower the impedance between the motor's frame and earth ground. Secure one end to motor and the other end to earth ground.

All paths must be conductive. When rebuilding a motor, overspray on the end bracket must be removed to ensure a conductive path to ground. Clean all fits. Use an Ohm meter to check resistance.

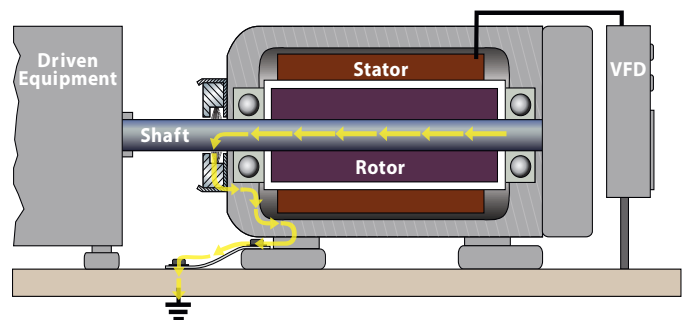

Patented Technology

AEGIS® High-Frequency Ground Strap Ensures Reliable Bond Between Motor Frame and System Ground

The AEGIS® Ring protects the motors bearings and prevents fluting and bearing failure and the High-Frequency Ground Strap (HFGS) ensures the reliable path to system ground.

Proper high-frequency (HF) grounding of VFD-driven motor systems is vital to prevent earth-level discontinuities between system components. It is especially critical in applications involving a motor and coupled equipment that are not mounted to a common baseplate. In such cases, effective HF grounding of all system components is necessary to equalize the potential between equipment frames and to prevent ground loops between the motor and coupled equipment.

Widely recognized as the most efficient path to ground for high frequency currents, grounding straps are recommended by major motor and drive manufacturers. AEGIS® High-Frequency Ground Straps ensure a very-low impedance path to ground from the frame of the motor for the high-frequency currents generated by VFD. Used in conjunction with AEGIS® Rings, which provide a safe path for damaging VFD-induced currents away from the motor's bearings to the motor's frame, AEGIS® HFGS bonding straps complete the path from motor's frame to system ground.

High-Frequency Ground Straps are designed with a tinned hole on one end (size based on NEMA/IEC frame) and a ring terminal on the opposite end to fit a 8mm screw. Standard lengths are available in 305mm and 610mm increments. Also available is a universal strap which includes a ring terminal on both ends. Longer straps and other terminations are available upon request. See page 53 for parts list.

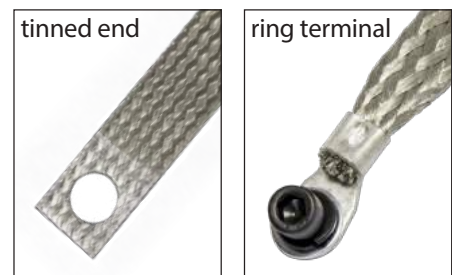

- BEARING CURRENTS
- MOTOR GROUNDING
- AEGIS® TECHNOLOGY
- LOW VOLTAGE MOTORS
- MED VOLTAGE MOTORS
- DC MOTORS
- INSTALL SHAFT PREP
- SHAFT VOLTAGE TESTING
- SELECT CORRECT SIZE
- PARTS LIST
- ENGINEERING SPEC

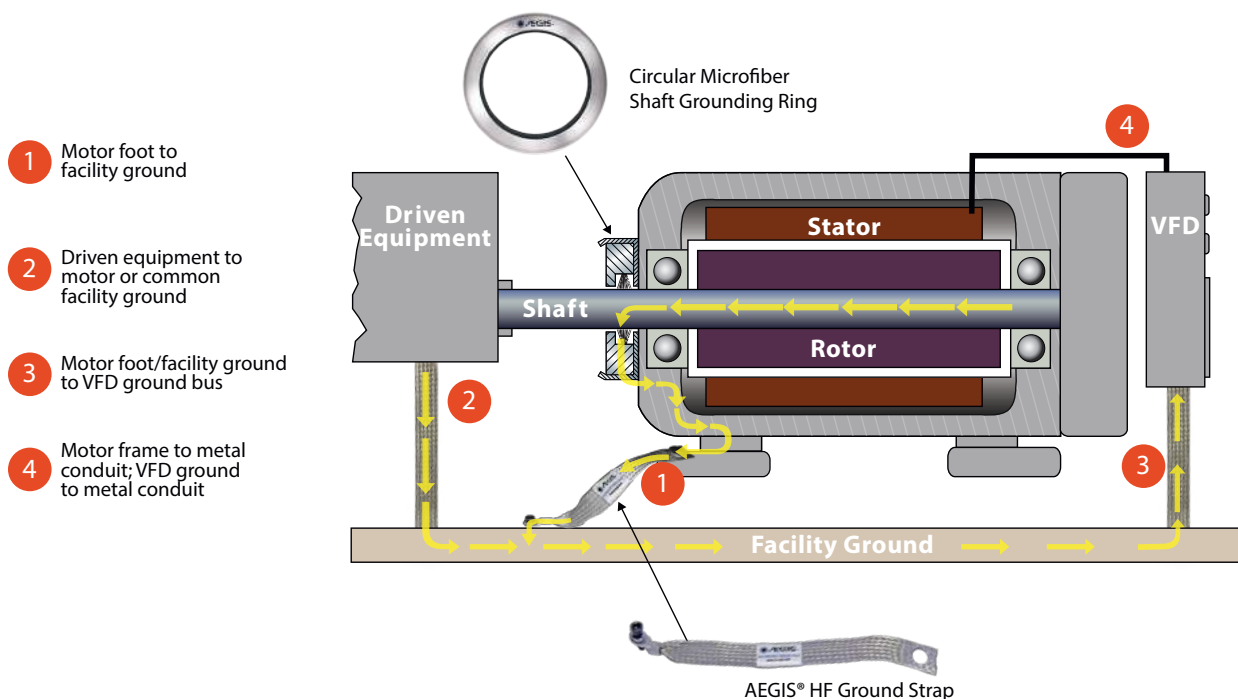

AEGIS® Shaft Grounding Rings Provide Both Contact and Noncontact Grounding The Only Product of its Kind



AEGIS® Shaft Grounding Ring uses Revolutionary Nanogap Technology

- Unique contact/non-contact design
- 360 degrees circumferential conductive microfiber ring
- Multiple row design – greatest reliability
- Ensures unmatched shaft grounding and performance



The AEGIS® Shaft Grounding Ring's patented Nanogap Technology ensures effective electrical contact even when physical contact is broken. Only AEGIS® Nanogap Technology provides both maintenance-free contact and noncontact bearing protection for the normal service life of the motor's bearings as well as the most reliable operation of any shaft grounding technology.

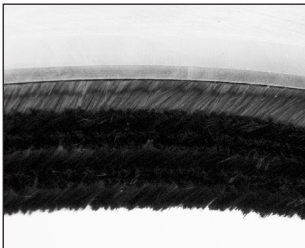

Proprietary Conductive Microfibers Last for the Service Life of the Motor

The AEGIS® Shaft Grounding Ring's unique design features hundreds of thousands to millions of specially engineered conductive microfibers that encircle the motor shaft. With so many electrical transfer points the ring provides continuous electrical contact, whether its fibers are physically touching the shaft or not. This patented "nanogap" technology enables both contact and noncontact shaft grounding — 100% of the time.

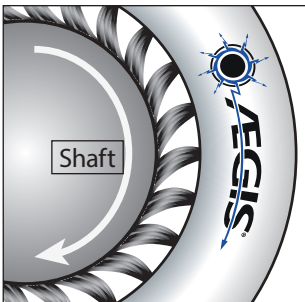

Specially Designed Microfibers Flex Without Breaking

Designed with specific mechanical and electrical characteristics that minimize wear and maintain conductivity, AEGIS® microfibers will last for the life of the motor. Based on wear of less than 0,025mm during 10,000 hours of testing, proven to withstand over 200,000 hours of continuous operation.

Wear-to-Fit™ Design

Through our patented design, AEGIS® conductive microfibers are a wear-to-fit design which ensures that the fibers don't "wear out" during the bearing's life. They exhibit minimal wear with the ability to flex without breaking. During the life of the ring the minimal wear characteristics ensure that the fibers only wear to the exact diameter of the motor's shaft and no further, maintaining the nanogap contact which allows the AEGIS® Shaft Grounding Rings to continue to operate effectively and protect the motor's bearings. In testing, they were proven to withstand 2 million direction reversals (to 1800 RPM) with no fiber fatigue or breakage.

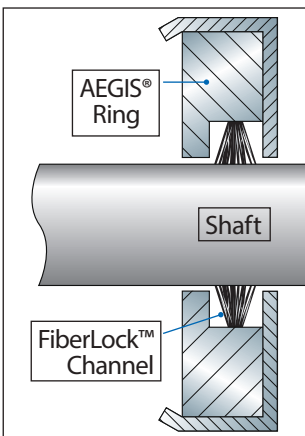

Patented FiberLock™ Channel Secures and Protects Fibers

AEGIS's patented, protective FiberLock™ channel locks the ring's conductive microfibers securely in place around the motor shaft, allowing them to flex without breaking. The channel also helps protect the fibers from excessive dirt, oil, grease, and other contaminants.

In severe duty environments install the AEGIS® Rings inside the motors or add a protective O-ring or V-slinger against the AEGIS® Ring's face (see page 33). For large motors or medium voltage motors specify the AEGIS® PROSLR (page 23) which incorporates an O-ring barrier built into the shaft grounding ring to protect against dirt or debris.



Ensures Unmatched Grounding With or Without Shaft Contact

At any point in time, the AEGIS® microfibers are in mechanical contact with the shaft and those that aren't are in nanogap proximity due its unique design. Thanks to the patented Electron Transport Technology™, all of the ring's fibers remain in electrical contact with the motor shaft providing unmatched grounding 100% of the time. This technology ensures electrical contact for the life of the motor through mechanical contact and three simultaneous nanogap noncontact current transfer processes. These processes ensure effective grounding regardless of the motor's speed. No other product works with and without contacting the motor shaft to provide the long term and maintenance-free bearing protection of the AEGIS® Ring.

Tunneling of Electrons

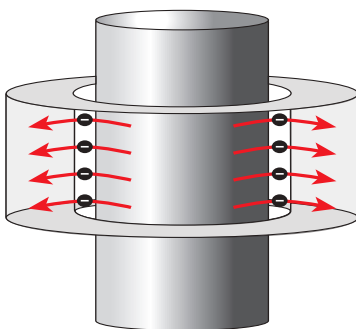

This mechanism is based on the ability of electrons to “tunnel” across an insulating barrier, and works for gaps smaller than 2 nm.

Field Emissions of Electrons

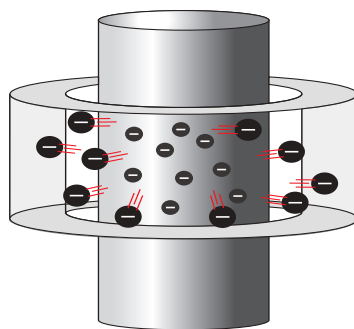

Field emission is a form of quantum tunneling whereby electrons move through a barrier in the presence of a high electric field. It provides grounding across gaps of 2 nm to 5 μm. The electric field from the shaft voltage creates the conditions for the AEGIS® ring fibers to take advantage of field emission electron transfer from the shaft.

Townsend Avalanche of Gaseous Ions

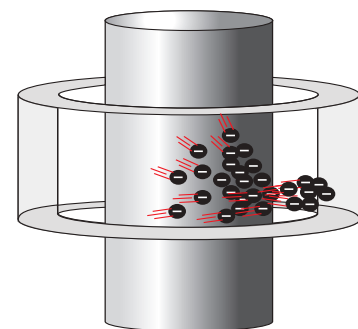

This process results from the cascading effect of secondary electrons released by collisions and the impact ionization of gas ions accelerating across gaps greater than 5 μm. This ionization creates negative and positive ions which neutralize the shaft voltage.

AEGIS® Shaft Grounding Ring vs. Contact-Only Brush

The chart below compares the design and performance characteristics of AEGIS® Rings to those of conventional and discrete-point grounding brushes that work only through contact with the motor shaft. Due to its patented design and proprietary conductive microfibers, the AEGIS® Ring maintains electrical contact with the motor shaft even if mechanical contact is broken. No other shaft grounding brush provides such exceptional bearing protection.

Performance Characteristic	AEGIS® Ring	Contact-Only Brush
Continuous circumferential ring design	Yes	No
Contact and Noncontact electrical shaft grounding	Yes	No
Protective fiber channel	Yes	No
Ultra-low wear fibers / wear-to-fit fiber design	Yes	No
Maintenance-free	Yes	No
Effective in presence of dust, dirt, oil, and grease	Yes	No



AEGIS® SGR for Low Voltage and AEGIS® PRO Series for Medium Voltage Motors

LOW VOLTAGE MOTORS UP TO 375kW

Supply voltage: 600 VAC or less
Recommended Technology: AEGIS® SGR

! Motors over 75 kW - recommend isolation of one bearing and AEGIS® SGR on the opposite bearing.



Description:

- Design Type: AEGIS® SGR
- Circumferential Conductive MicroFiber rows in FiberLock™ Channel
- Rows of fiber: 2
- Fiber overlaps shaft 0,76mm
- OAL: 7,5mm
- OD: listed in AEGIS® Parts List

Mounting:

- Internal or External
- Select based on shaft diameter
- Split and Solid versions available
- Custom brackets optional

AEGIS® SGR Current Capability Chart

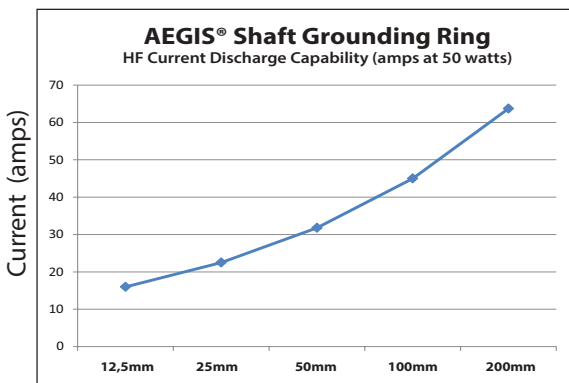

MEDIUM VOLTAGE MOTORS AND LOW VOLTAGE MOTORS > 375kW

Recommended Technology: AEGIS® PRO Series

! Recommend isolation of one bearing and AEGIS® PRO Series on the opposite bearing.



6 rows of Conductive MicroFiber

Description:

- Design Type: AEGIS® PRO Series
- Circumferential Conductive MicroFiber rows in FiberLock™ Channel
- Rows of fiber: 6
- Fiber overlaps shaft 0,76mm
- Varies by PRO Ring style
- OD: Shaft + (refer to drawing)

Mounting:

- Internal or External
- Select based on shaft diameter
- Split and Solid versions available
- Custom brackets optional

AEGIS® PRO Series Current Capability Chart

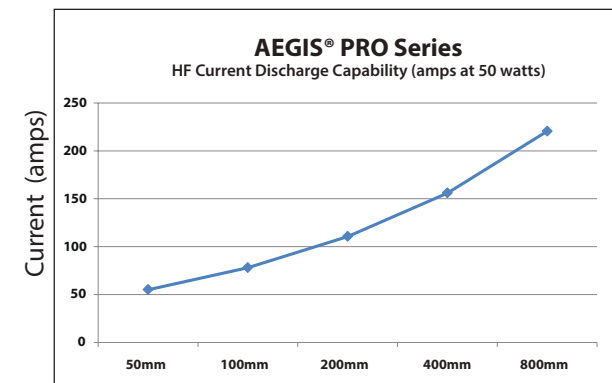

Patented Technology

Manufacturer's Specification

Fiber Flexibility	AEGIS® Rings are constructed with patented AEGIS® FiberLock™ channel to allow conductive micro fibers to bend and flex within their elastic design limits. Multiple rows of fiber are distributed 360 degrees inside the FiberLock™ channel to provide maximum shaft surface contact. Fiber length is designed with an optimal shaft overlap.
Fiber wear	Usually less than 0,03mm in 10.000 hours. Fiber wear length is designed for expected life of 200.000+ hours based on testing. Wear rate may vary depending on conditions in individual applications. Fibers retain contact/noncontact function.
Friction	Little or no frictional axial or radial fiber pressure applied to shaft. Extremely light contact only. Designed for minimal friction with no reduction in motor performance.
Shaft Surface Finish	Ra 3.3 micron finish max
AEGIS® Shaft Grounding Ring Maintenance Requirements	The AEGIS® Ring does not require maintenance. The shaft must remain conductive for shaft current discharge.
Replacement	Install new AEGIS® Ring whenever bearings are replaced on inverter-driven motors.
Oil and Grease on Motor Shaft	Small amounts of oil and/or grease are acceptable if the shaft surface remains conductive. Fibers are designed to maintain contact with the motor shaft and “sweep” oil away from surface.
Dirt/dust	Small amounts of dust and/or small particles are acceptable. Fibers “sweep” particles from shaft surface during operation. Shaft surface must remain conductive.
Directional rotation	Motor may be operated in clockwise or counter clockwise rotation. Motor may change directional rotation without limitations.
Eccentricity	0,25mm Total Indicator Runout in area where AEGIS® Ring is installed.
Maximum surface rate/RPM	No Maximum rating - There is no theoretical RPM limit as there is virtually no frictional contact with the shaft at high RPM. Verify specific applications with AEGIS® engineering.
Maximum temperature rating	210 ° C - Verify application specific temperatures with AEGIS® engineering.
Minimum temperature rating	-80 ° C - Verify application specific temperatures with AEGIS® engineering.
Humidity	0 to 90% - Verify application specific acceptable humidity with AEGIS® engineering
Surface Conductivity	Coating the shaft with AEGIS® Colloidal Silver Shaft Coating (CS015) will enhance surface conductivity and help prevent rust/corrosion.
RoHS Test Results Directive 2002/95/EC for the Restriction of the use of certain Hazardous Substances in electrical and electronic equipment applies	<p>All materials used in manufacture of AEGIS® Rings are in compliance with Directive 2002/95/EC, Restriction of the use of certain Hazardous Substances in electrical and electronic equipment. No RoHS banned substances are present in excess of the maximum concentration values (MCV).</p> <ol style="list-style-type: none"> Following substances were found to be less than 0,1% by weight in homogeneous materials (required by RoHS directive): Lead (Pb) Mercury (Hg) Hexavalent chromium (Cr(VI)) Polybrominated biphenyl (PBB) Polybrominated diphenyl ether (PDPE) Following substance is less than 0,01% by weight in homogeneous materials (required by RoHS directive): Cadmium (Cd) <p>Note: Request RoHS Certification Letter from sales@est-aegis.com or call 1-866-738-1857</p>
Hazardous areas	Not certified for external mounting in hazardous environments (Class 1 Division 1, Division 2 or Class 1 Zone 1, Zone 2). AEGIS® Shaft Grounding Rings may be installed inside an Explosion Proof enclosure per IEEE Std 303™-2004 or inside an XP Motor.
CE and UL requirements	AEGIS® Rings are classified as a “component” and as such are not subject to the requirements of any Directive. The application of CE or UL Mark is not applicable to this component.

BEARING CURRENTS

MOTOR GROUNDING

AEGIS® TECHNOLOGY

LOW VOLTAGE MOTORS

MED VOLTAGE MOTORS

DC MOTORS

INSTALL SHAFT PREP

SHAFT VOLTAGE TESTING

SELECT CORRECT SIZE

PARTS LIST

ENGINEERING SPEC



Motors up to and including 75 kW

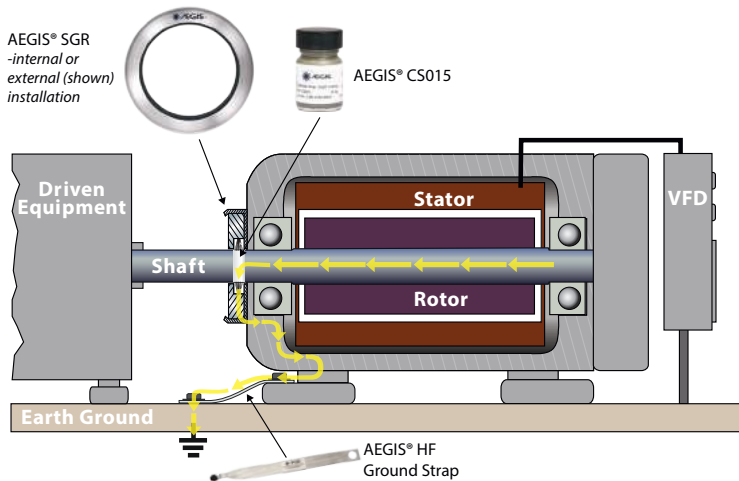

Protects motor bearings and bearings in attached equipment.

Low Voltage Motors:

General recommendations: For induction motors operated on PWM IGBT VFD's either foot mounted, C-face or D-flange mounted motors with single row radial ball bearings on both ends of the motor. Motors may be installed either horizontally or vertically in the customer's application.

- Install one AEGIS® SGR Shaft Grounding Ring on either the drive end or the non-drive end of the motor to discharge capacitive induced shaft voltage.
- AEGIS® SGR may be installed either internally or externally.
- AEGIS® Colloidal Silver Shaft Coating (PN# CS015) is recommended to be applied on motor shaft where fibers touch.

! Product recommendation: AEGIS® SGR

! Follow all safety precautions. GHS SDS available for download at www.est-aegis.com

Motors Greater than 75 kW

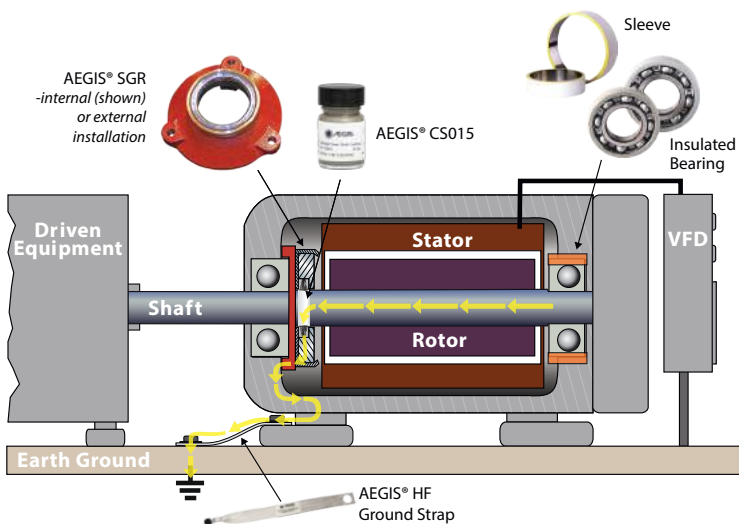

Install AEGIS® Ring on opposite end from insulation

Low Voltage Motors:

For horizontally mounted motors with single row radial ball bearings on both ends of the motor:

- Non-Drive end: Bearing housing must be isolated with insulated sleeve or coating or use insulated ceramic or hybrid bearing to disrupt circulating currents.
- Drive end: Install one AEGIS® Shaft Grounding Ring.
- AEGIS® Ring can be installed internally on the back of the bearing cap or externally on the motor end bracket.
- AEGIS® Colloidal Silver Shaft Coating (PN# CS015) is recommended to be applied on motor shaft where fibers touch.

! Product recommendation:

♦ **Low Voltage Motors up to 375 kW: AEGIS® SGR**

♦ **Low Voltage Motors over 375 kW: AEGIS® PRO Series**



Patented Technology

Motors Where Both Bearings are Insulated - Any kW

Low Voltage Motors:

- Install one AEGIS® Shaft Grounding Ring, drive end preferred, to protect bearings in attached equipment (gearbox, pump, fan bearing and encoder, etc...).
- AEGIS® Ring can be installed internally on the back of the bearing cap or externally on the motor end bracket.
- Colloidal Silver Shaft Coating PN CS015 is required for this type of application.



Product recommendation:

- ♦ Low Voltage Motors: AEGIS® SGR
- ♦ Low Voltage Motors over 375 kW: AEGIS®PRO Series



Bearings in attached equipment may be at risk from VFD induced shaft voltage unless AEGIS® Shaft Grounding is installed.

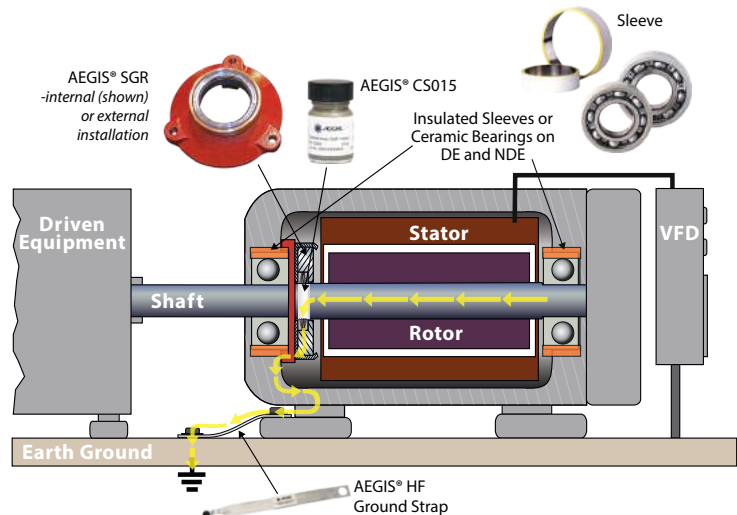

Motors with Cylindrical Roller, Babbitt or Sleeve Bearings

Low Voltage Motors:

- Cylindrical Roller Bearing, Babbitt, or Sleeve bearing: Bearing housing should be isolated or use insulated bearing.
- Motors with insulated cylindrical roller bearing DE: Install AEGIS® Shaft Grounding Ring on opposite drive end (NDE).
- AEGIS® Ring can be installed internally on the back of the bearing cap or externally on the motor end bracket.
- Colloidal Silver Shaft Coating PN CS015 is required for this type of application.



Product recommendation:

- ♦ Low Voltage Motors: AEGIS® SGR
- ♦ Low Voltage Motors over 375 kW: AEGIS®PRO Series

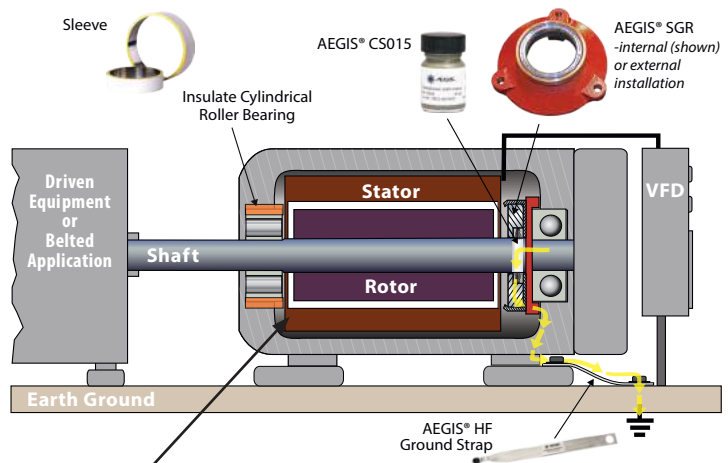

Note: Insulating the DE cylindrical roller bearing is preferred. However, if this is not possible, then insulate the NDE bearing instead and install an AEGIS® Ring on the DE (cylindrical roller bearing side).

AEGIS® Ring must be installed opposite side of insulation.



Vertical Solid Shaft Motors up to and including 75 kW

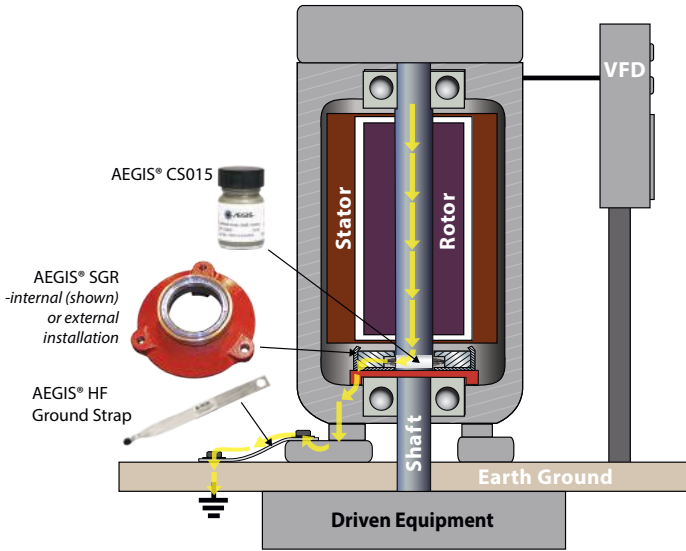

Low Voltage Motors:

- Lower Bearing: Install one AEGIS® SGR Shaft Grounding Ring.
- AEGIS® SGR can be installed internally on the back of the bearing cap or externally on the motor end bracket.
- Colloidal Silver Shaft Coating PN CS015 is required for this type of application.

! Product recommendation: AEGIS® SGR

! Follow all safety precautions. MSDS available for download at www.est-aegis.com

Vertical Solid Shaft Motors Greater than 75 kW

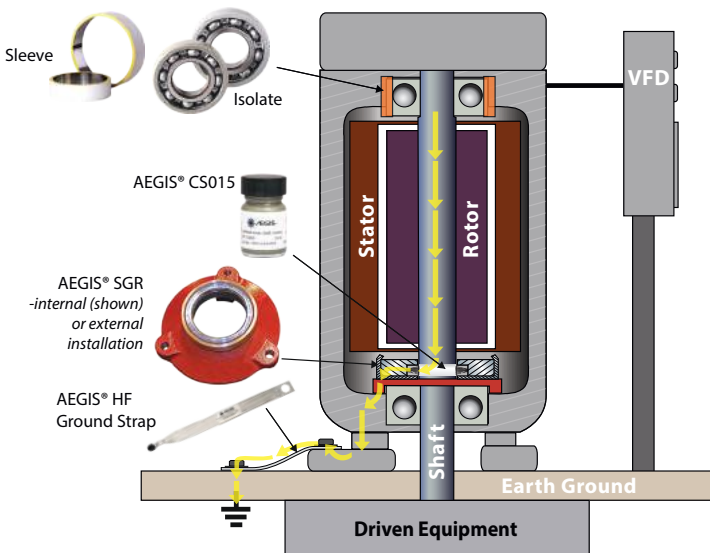

Low Voltage Motors:

- Upper Bearing: Bearing journal must be isolated or insulated ceramic or hybrid ceramic bearing installed.
- Bottom Bearing: Install one AEGIS® Shaft Grounding Ring.
- AEGIS® Ring can be installed internally on the back of the bearing cap or externally on the motor end bracket.
- Colloidal Silver Shaft Coating PN CS015 is required for this type of application.

! Product recommendation:
 ♦ Low Voltage Motors: AEGIS® SGR
 ♦ Low Voltage Motors over 375 kW: AEGIS® PRO Series



Patented Technology

Vertical (Hollow & Solid Shaft) Thrust Handling Motors up to and including 75 kW

Low Voltage Motors:

- Lower Bearing: Install one AEGIS® SGR Shaft Grounding Ring.
- AEGIS® SGR can be installed internally on the back of the bearing cap.
- Colloidal Silver Shaft Coating PN CS015 is required for this type of application.

! Product recommendation: AEGIS® SGR

Note: For external installation, the AEGIS® Ring must run on the motor or pump shaft at the lower bearing. Ring must not be mounted around the steady bushing.

Upper bearing may be isolated with insulated bearing carrier for added protection.

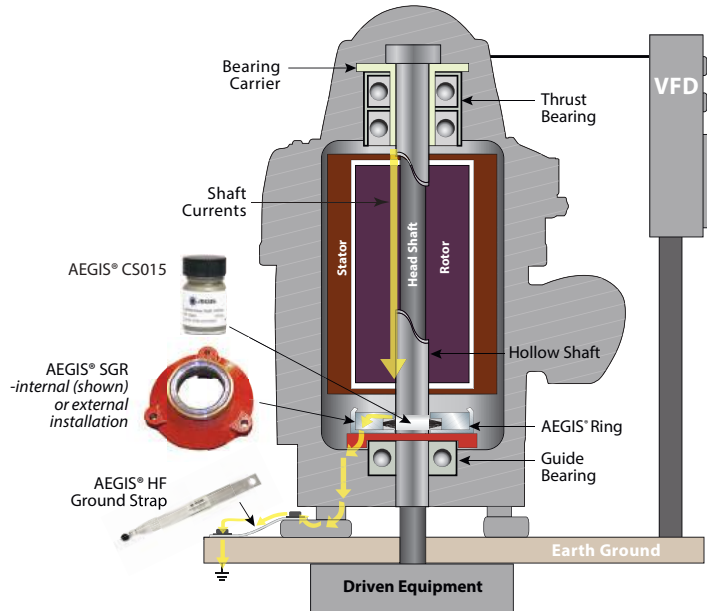

Vertical (Hollow & Solid Shaft) Thrust Handling Motors Greater than 75 kW

Low Voltage Motors:

- Upper Bearing: Bearing carrier must be isolated or insulated ceramic or hybrid ceramic bearing installed.
- Lower Bearing: Install one AEGIS® Shaft Grounding Ring.
- AEGIS® Ring can be installed internally on the back of the bearing cap.
- Colloidal Silver Shaft Coating PN CS015 is required for this type of application.

! Product recommendation:

- ♦ Low Voltage Motors: AEGIS® SGR
- ♦ Low Voltage Motors over 375 kW: AEGIS®PRO Series

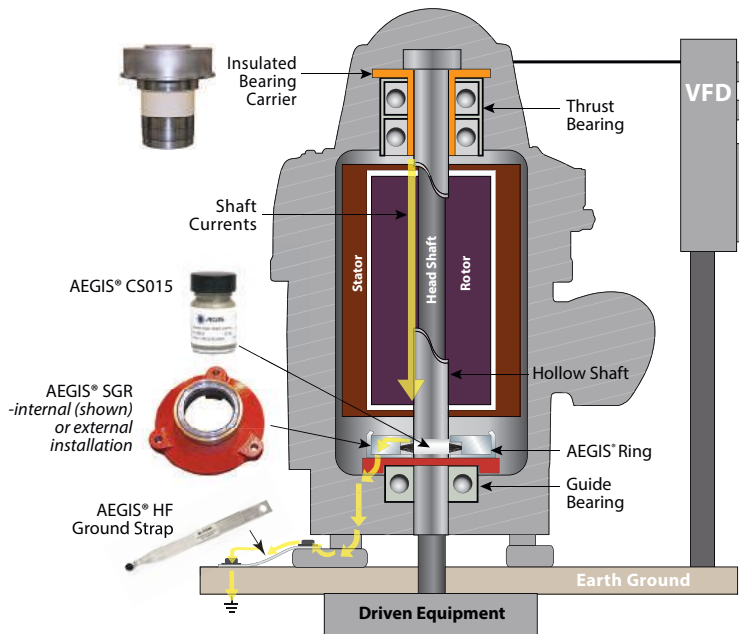

BEARING CURRENTS

MOTOR GROUNDING

AEGIS® TECHNOLOGY

LOW VOLTAGE MOTORS

MED VOLTAGE MOTORS

DC MOTORS

INSTALL SHAFT PREP

SHAFT VOLTAGE TESTING

SELECT CORRECT SIZE

PARTS LIST

ENGINEERING SPEC

BEARING CURRENTS

MOTOR GROUNDING

AEGIS® TECHNOLOGY

LOW VOLTAGE MOTORS

MED VOLTAGE MOTORS

DC MOTORS

INSTALL SHAFT PREP

SHAFT VOLTAGE TESTING

SELECT CORRECT SIZE

PARTS LIST

ENGINEERING SPEC

AEGIS® PRO Series - Shaft Grounding Rings For Maximum Bearing Protection

The AEGIS® PRO Series design provides reliable shaft grounding for medium voltage applications, generators and turbines to divert harmful shaft voltages to ground and extend bearing life. Install the AEGIS® PRO on the DE and insulate the bearing on the opposite end (NDE) for best results. Large motors and generators often have much higher induced shaft voltages and bearing currents. The six circumferential rows of conductive microfiber provide the extra protection for these high current applications.

Generators may experience current surges which can cause electrical arcing in their bearings and equipment. The AEGIS® PRO Rings have a high current capable design and can discharge these currents.

Designed for:

- Large frame low-voltage motors: 375 kW or greater
- Medium-voltage motors
- DC motors: 225 kW or greater

Specifications:

- Available in shaft diameters from 63,5mm to 762mm
- Circumferential Conductive MicroFiber rows in FiberLock™ Channel
- Rows of fiber: 6
- Fiber overlaps shaft 0,76mm
- Ships with CS015 AEGIS® Colloidal Silver Shaft Coating

Options:

- Solid and split ring designs
- Monitoring ring option for voltage monitoring
- Stock brackets and stand-off kits
- Custom brackets available

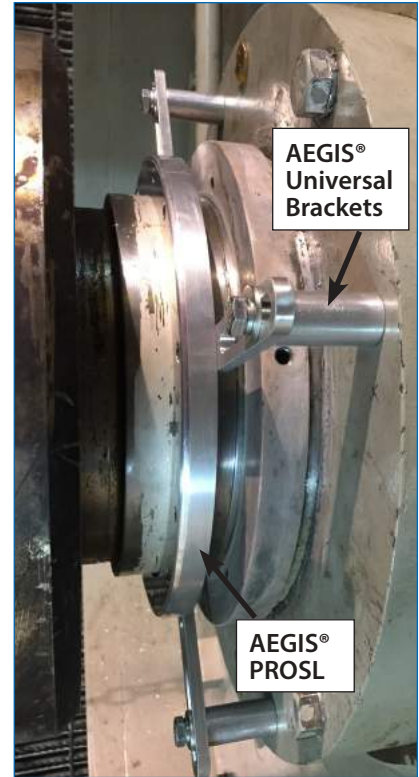

AEGIS® PROSL with Universal Brackets

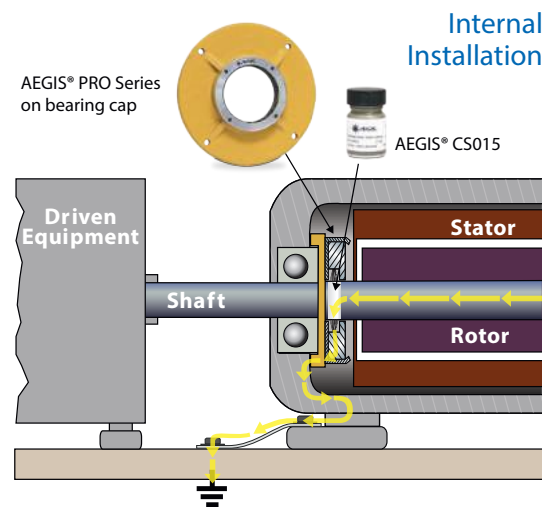
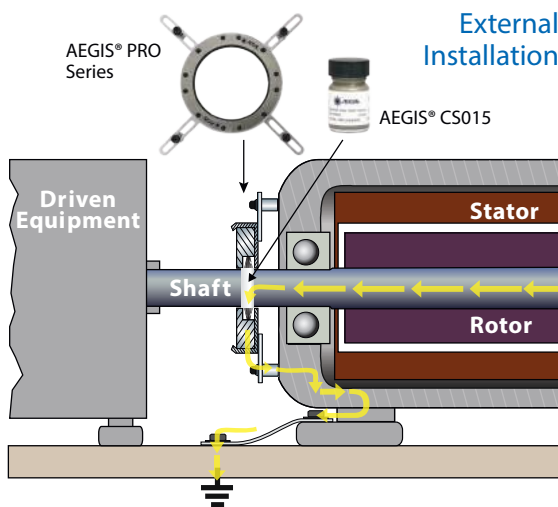

Patented Technology

AEGIS® PRO Series - Shaft Grounding Ring

AEGIS® PROSL

The AEGIS® PROSL is a high current capable AEGIS® PRO Series Shaft Grounding Ring for large motors, generators and turbines operated by VFDs. The slim design and flexible installation options allow for adaptation to virtually all large motors.

Specifications

Designs: Solid, Split and Press Fit
 Shaft Dia: 63,5mm to 400mm
 OD: Shaft Dia + 47,24mm
 OAL: 16,51mm MAX assembled with mounting screws
 Mounting: Supplied with screws for bolt through mounting
 Metric: M4 x 0,7 x 25mm Flat Head Cap Screws

Optional Universal Brackets for easy mounting.



AEGIS® PROSLR

Severe Duty motors are operated in general processing industry applications requiring protection from severe environmental operating conditions - often where there is debris, powder, dirt, liquids, lubricants or other contaminants. For these applications the AEGIS® PROSLR incorporates an O-ring dust and debris barrier which will prevent ingress of materials that could interfere with the contact of the conductive microfibers to the motor's shaft.

Note: When the AEGIS® PROSLR is installed inside the motor the O-ring barrier will prevent grease from clogging the fibers in an over-lubricated condition.

Specifications

Designs: Solid and Split
 Shaft Dia: 63,5mm to 400mm
 OD: Shaft Dia + 47,24mm
 OAL: 19,68mm assembled with mounting screws
 Mounting: Supplied with screws for bolt through mounting
 Metric: Solid Ring M4 x 0,7 x 25mm FHCS, Split Ring M4 x 0,7 x 30mm FHCS

Optional Universal Brackets for easy mounting.



AEGIS® PROMAX

The AEGIS® PROMAX is designed for installation on the most critical and largest motors, generators and turbines. Scalable to any shaft diameter over 400mm, this high current capable AEGIS® PROMAX Shaft Grounding Ring is custom engineered for each application to ensure the best bearing protection possible.

Specifications

Designs: Split Ring only
 Shaft Dia: 400mm to 762mm
 OD: Shaft Dia + 76,2mm
 OAL: 47,62mm assembled with mounting screws
 Mounting: Supplied with (4) M8 x 1,25 x 50 Socket Head Cap Screws for bolt through mounting

Custom brackets available upon request



AEGIS® PRO Series Shaft Grounding Ring

AEGIS® PROMR



The AEGIS® PROMR “monitoring ring” combines the AEGIS® PROSL with an additional isolated SGR ring that can be used as a monitoring device. The PROSL channels the voltages and currents safely to ground while the monitoring SGR ring measures voltage on the shaft and is not grounded. A phenolic plate between the 2 rings is used to isolate the monitoring ring.

For shaft diameter of 63,5mm to 400mm.

- Designs: Solid and Split
- OD: Shaft Dia + 47,24mm
- OAL: 33,32mm assembled with mounting screws
- Mounting: Supplied with screws for bolt through mounting
Metric Screws: M4 x 0,7 x 25mm Flat Head Cap Screws

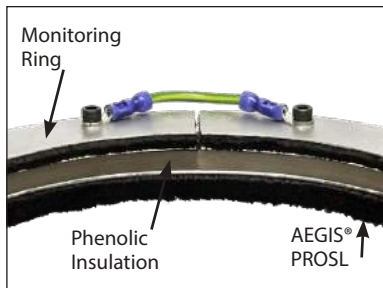

Optional Universal Brackets for easy mounting.

Optional Mounting Brackets for AEGIS® PRO Series

For AEGIS® PROSL, PROSLR, PROMR



AEGIS® PROSL Universal Brackets

Kit includes brackets, four different spacer lengths and hardware for each. See parts list for details (page 50).

Custom Brackets/Installation Examples

Contact our Engineering Team for special mounting applications.



Custom Split Mounting Plate with tie bars



Bearing Cap Mounting



Custom Mounting Brackets



Patented Technology

Motors Greater than 75 kW

Medium Voltage Motors:

For horizontally mounted motors with single row radial ball bearings on both ends of the motor:

- Non-Drive end: Bearing housing must be isolated with insulated sleeve or coating or use insulated ceramic or hybrid bearing to disrupt circulating currents.
- Drive end: Install one AEGIS® Shaft Grounding Ring .
- AEGIS® Ring can be installed internally on the back of the bearing cap or externally on the motor end bracket.
- AEGIS® Colloidal Silver Shaft Coating (PN# CS015) is recommended to be applied on motor shaft where fibers touch.

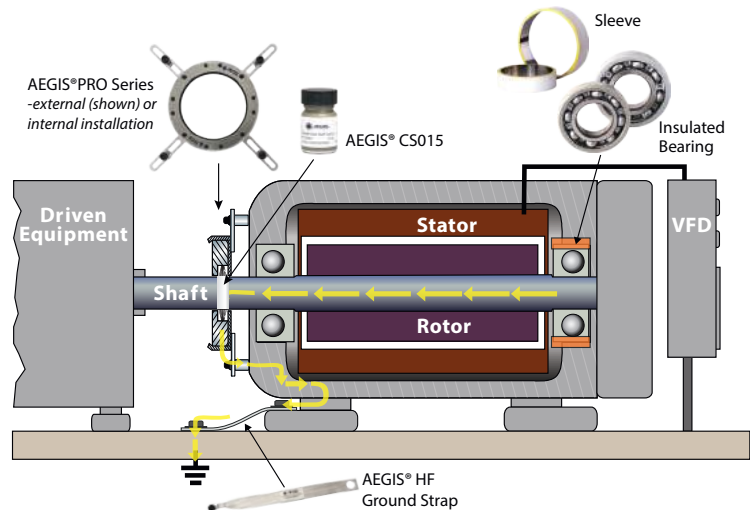

Install AEGIS® Ring on opposite end from insulation

! Product recommendation:
AEGIS® PRO Series

Motors Where Both Bearings are Insulated - Any kW

Medium Voltage Motors:

- Install one AEGIS® Shaft Grounding Ring, drive end preferred, to protect bearings in attached equipment (gearbox, pump, fan bearing and encoder, etc...).
- AEGIS® Ring can be installed internally on the back of the bearing cap or externally on the motor end bracket.
- Colloidal Silver Shaft Coating PN CS015 is required for this type of application.

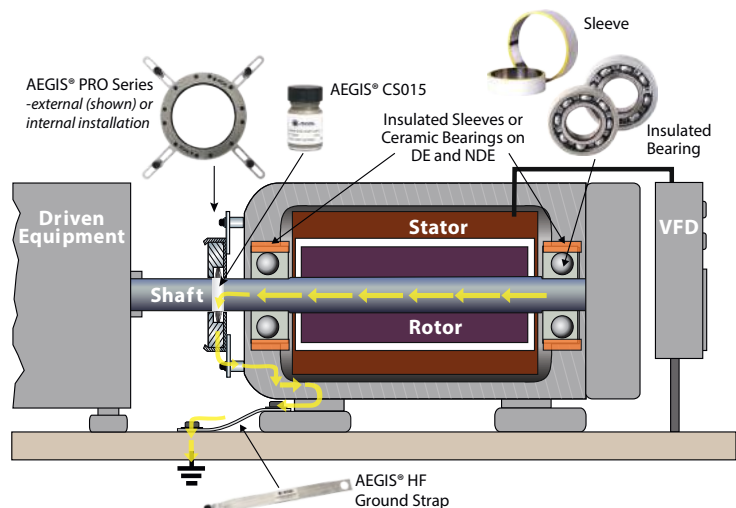

STOP Bearings in attached equipment may be at risk from VFD induced shaft voltage unless AEGIS® Shaft Grounding is installed.

! Product recommendation:
AEGIS® PRO Series



BEARING CURRENTS

MOTOR GROUNDING

AEGIS TECHNOLOGY

LOW VOLTAGE MOTORS

MED VOLTAGE MOTORS

DC MOTORS

INSTALL SHAFT PREP

SHAFT VOLTAGE TESTING

SELECT CORRECT SIZE

PARTS LIST

ENGINEERING SPEC

Motors with Cylindrical Roller, Babbitt or Sleeve Bearings

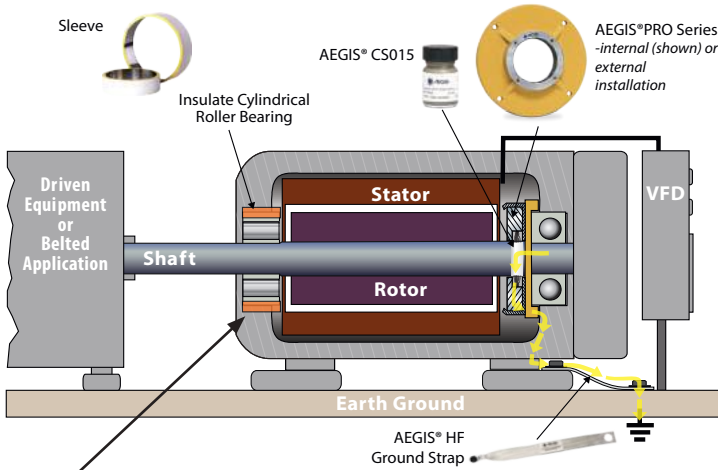

Note: Insulated DE bearing is preferred. However, if this is not possible then insulate the NDE bearing instead and install an AEGIS® Ring on the DE (cylindrical roller bearing side).

AEGIS® Ring must be installed opposite side of insulation.

Medium Voltage Motors:

- Cylindrical Roller Bearing, Babbitt, or Sleeve bearing: Bearing housing should be isolated or use insulated bearing.
- Motors with insulated cylindrical roller bearing DE: Install AEGIS® Shaft Grounding Ring on opposite drive end (NDE).
- AEGIS® Ring can be installed internally on the back of the bearing cap or externally on the motor end bracket.
- Colloidal Silver Shaft Coating PN CS015 is required for this type of application.

Product recommendation:
AEGIS® PRO Series

Vertical Solid Shaft Motors Greater than 75 kW

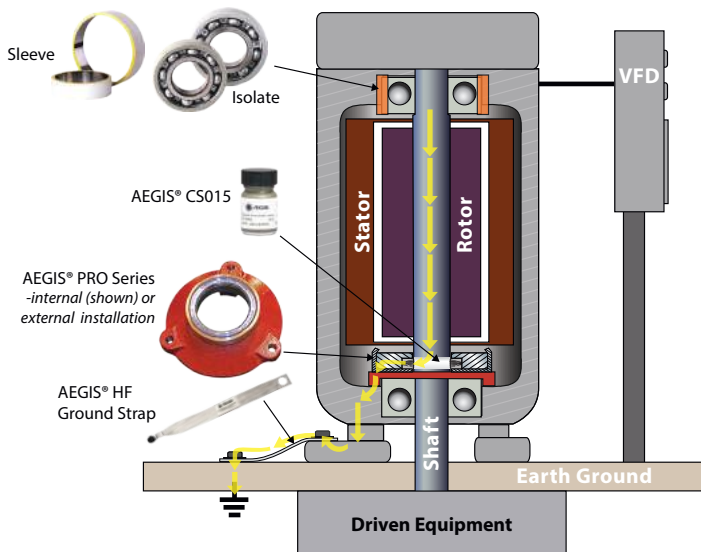

Medium Voltage Motors:

- Upper Bearing: Bearing journal must be isolated or insulated ceramic or hybrid ceramic bearing installed.
- Bottom Bearing: Install one AEGIS® Shaft Grounding Ring.
- AEGIS® Ring can be installed internally on the back of the bearing cap or externally on the motor end bracket.
- Colloidal Silver Shaft Coating PN CS015 is required for this type of application.

Product recommendation:
AEGIS® PRO Series



Patented Technology

Vertical Hollow Shaft Motors Greater than 75 kW

Medium Voltage Motors:

- Upper Bearing: Bearing carrier must be isolated or insulated ceramic or hybrid ceramic bearing installed.
- Lower Bearing: Install one AEGIS® Shaft Grounding Ring.
- AEGIS® Ring can be installed internally on the back of the bearing cap.
- Colloidal Silver Shaft Coating PN CS015 is required for this type of application.

! Product recommendation:
AEGIS® PRO Series

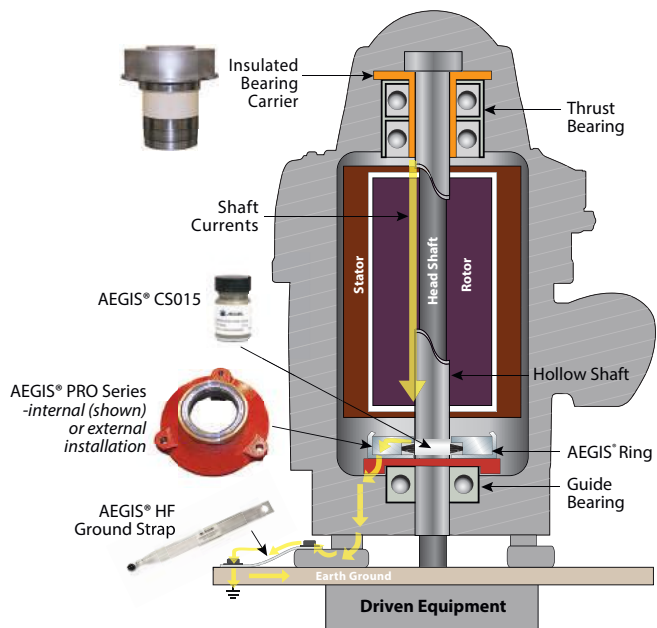

All AEGIS® PRO Series Rings are custom-manufactured to the measurements provided

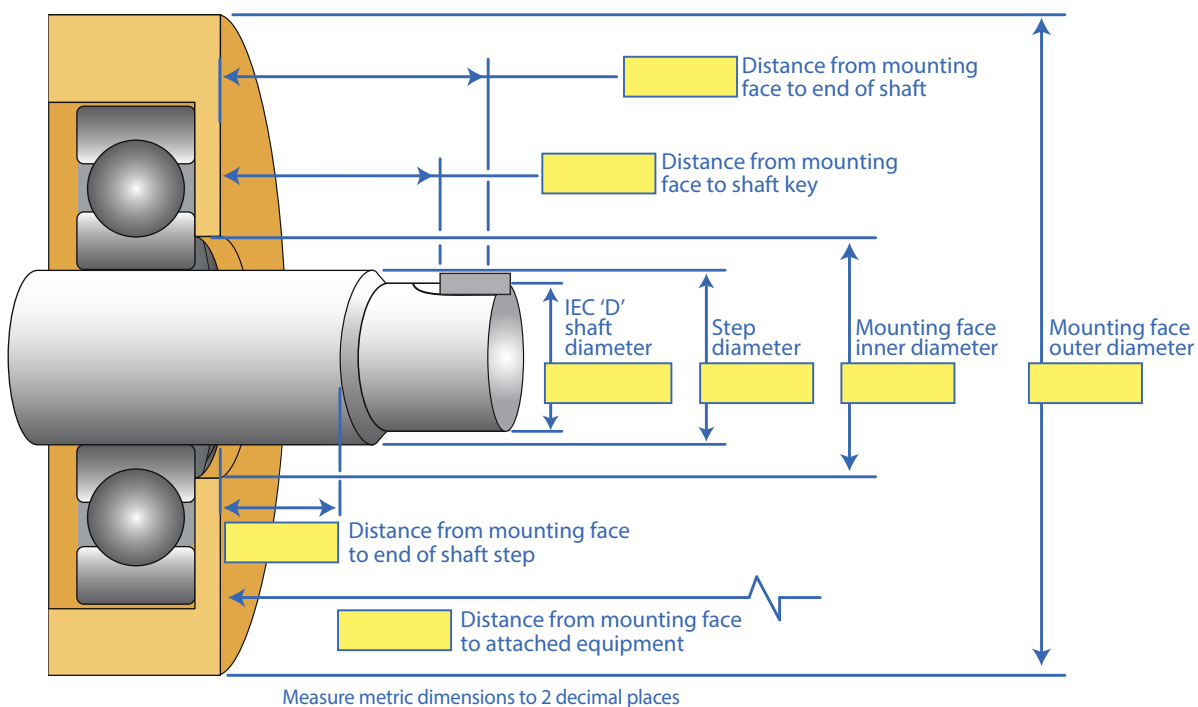

BEARING CURRENTS

MOTOR GROUNDING

AEGIS® TECHNOLOGY

LOW VOLTAGE MOTORS

MED VOLTAGE MOTORS

DC MOTORS

INSTALL SHAFT PREP

SHAFT VOLTAGE TESTING

SELECT CORRECT SIZE

PARTS LIST

ENGINEERING SPEC

AEGIS® Shaft Grounding for DC Motors

DC motors when operated on drives may also require bearing protection from induced shaft voltages. Capacitive induced shaft voltages may be hundreds of volts peak-to-peak and depending on the drive will increase in amplitude as the speed of the motor is increased. If there is no shaft grounding ring installed, the voltages may discharge through the bearings causing EDM pitting and fluting failure. In addition, circulating currents from magnetic dissymmetry may exist on DC motors over 7,5 kW ⁽¹⁾. This would necessitate the insulation of the NDE bearing, with an AEGIS® Shaft Grounding Ring installed on the opposite end of the motor.

(1) EASA web seminar: Dealing with Shaft and Bearing Currents, Thomas H. Bishop, P.E., Electrical Apparatus Service Association, January 19, 2011

Recommendation: Install AEGIS® SGR on the DE of the DC motor for all motors up to 225 kW. For DC motors over 7,5 kW, also insulate the NDE bearing.



AEGIS® PRO Series Shaft Grounding Ring for Large DC Motors 225 kW and Greater

Large DC motors over 225 kW have higher shaft voltages and currents and require the AEGIS® PRO Series installed on the DE of the motor. In addition, the NDE bearing should have insulation to prevent circulating currents.



DC Motor - Before and After Testing with AEGIS® Installed 260 kW DC Motor - DC Inverter Drive

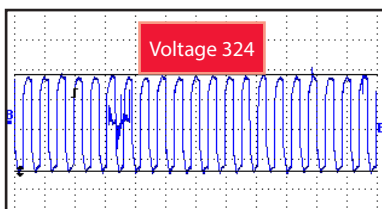

Capacitive induced shaft voltage before bearing current discharge through the bearings. Square wave from DC SCR drive.

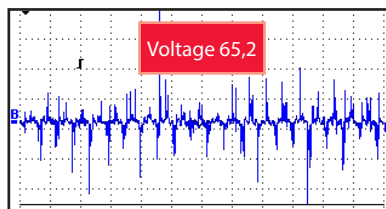

No Shaft Grounding
Volts: 65,2 V pk-pk
Bearing discharges (EDM)

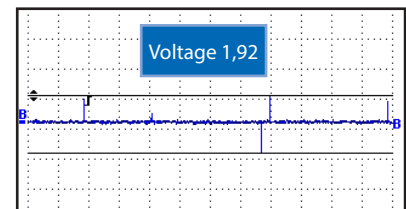

AEGIS® Shaft Grounding
Volts: 1,92 V pk-pk
Discharge through AEGIS® Shaft Grounding Ring



DC Motors up to and including 7,5 kW - Operated on DC Inverter⁽¹⁾

DC Motors:

- Install one AEGIS® SGR Shaft Grounding Ring on either the drive end or the non-drive end of the motor to discharge induced shaft voltage.
- AEGIS® SGR should be installed internal to the motor if possible but may also be attached externally to the motor's end bracket.
- AEGIS® Colloidal Silver Shaft Coating (PN# CS015) is recommended to be applied on motor shaft where fibers touch.

! Product recommendation: AEGIS® SGR

! Follow all safety precautions. MSDS available for download at www.est-aegis.com

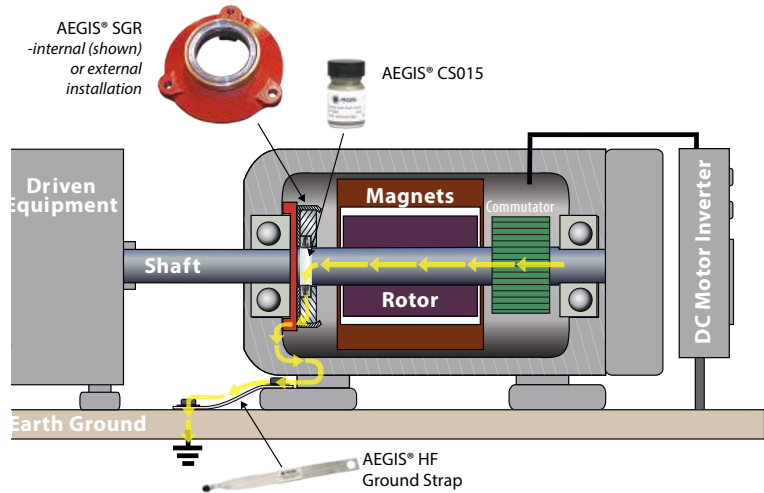

DC Motors Greater than 7,5 kW - Operated on DC Inverter

DC Motors:

- Non-Drive end: Bearing housing must be isolated with insulated sleeve or coating or use insulated ceramic or hybrid bearing to disrupt circulating currents.
- Drive end: Install one AEGIS® Shaft Grounding Ring to discharge induced shaft voltage.
- AEGIS® Ring should be installed internal to the motor if possible but may also be attached externally to the motor's end bracket.
- AEGIS® Colloidal Silver Shaft Coating (PN# CS015) is recommended to be applied on motor shaft where fibers touch.

! Product recommendation:

- ♦ **DC motors from 7,5 kW to 225 kW: AEGIS® SGR**
- ♦ **DC motors over 225 kW: AEGIS®PRO Series**

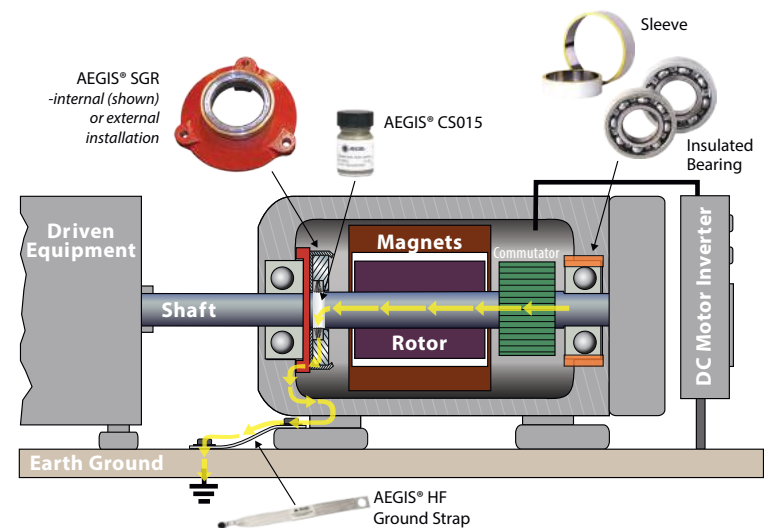

(1) EASA web seminar: Dealing with Shaft and Bearing Currents, Thomas H. Bishop, P.E., Electrical Apparatus Service Association, January 19, 2011



AEGIS® Installation - Internal

AEGIS® Shaft Grounding Rings are ideally installed on the inside of the motor to provide protection from ingress of dirt and dust. Motor manufacturers commonly use this installation as a best practice in stock catalog motors equipped with AEGIS® rings.



Follow all safety precautions. GHS SDS for CS015 and EP2400 available for download at www.est-aegis.com



Follow AEGIS® best practices for motor shaft preparation and ring installation. Use AEGIS® Colloidal Silver Shaft Coating when installing AEGIS® rings to enhance the shaft conductivity and help prevent oxidation.



Press Fit Installation:

- Press into bearing retainer
- Press into custom bracket

Bore Specification: 0,05 mm - 0,10 mm interference

- Ring OD tolerance +0 / -0,025 mm
- Bore tolerance +0,025 / -0 mm



Bolt-through installation:

- Press into bearing retainer
- Press into custom bracket



Do not use non-conductive thread-lock

Drill/tap holes per AEGIS® Ring drawing location

- Flat head cap screws
- Socket head cap screws/lock washer



Use EP2400 Conductive Epoxy if thread lock is needed to secure the screws in place.



Photo courtesy of Independent Electric

In some motors it may be desirable to attach an additional machined spacer to locate the ring further away from the bearing grease cavity.

A grease seal may be added to reduce grease ingress to the fibers.

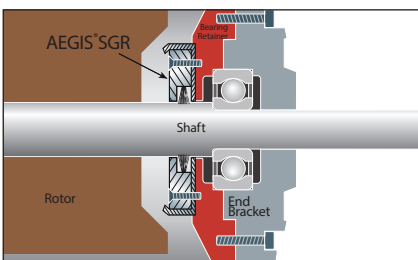

Common AEGIS® Ring installation internal to the motor is on the motor's bearing retainer. Installation can be done with bolt through hardware or AEGIS® Conductive Epoxy.

For epoxy installation, bearing retainer must be clean & free of any coatings, paint, or other nonconductive material where AEGIS® SGR will be mounted. This is the discharge path to ground therefore metal to metal contact is essential.



Epoxy Mounting – Internal

AEGIS® Conductive Epoxy was specially developed and tested to stringent vibration and pull test requirements to ensure a strong and reliable long term adhesive bond.



Do not use a substitute epoxy as only the AEGIS® EP2400 has been tested and approved for AEGIS® ring installation.



AEGIS® Installation - External

AEGIS® Shaft Grounding Rings may be installed on the outside of the motor but care must be taken to protect the ring from excessive ingress of dirt and dust.

! Follow AEGIS® best practices for motor shaft preparation and ring installation. Use AEGIS® Colloidal Silver Shaft Coating when installing AEGIS® rings to enhance the shaft conductivity and help prevent oxidation.

An O-ring or V-slinger may be installed against the AEGIS® Ring to help prevent excessive ingress of dirt, dust or liquid.

Standard bracket or uKIT bracket Installation:

1. Standard Brackets (3 or 4 depending on ring size)
2. uKIT includes various bracket options
3. Custom brackets available

To view product line or download the AEGIS® Catalog visit www.est-aegis.com



Large Severe Duty AC and DC Motors: These motors are operated in severe environmental conditions where there is debris, powder, dirt, liquids, lubricants or other contaminants which can collect around the shaft of the motor. For these applications the AEGIS® PROSLR incorporates an O-ring dust and debris barrier to prevent ingress of these materials. See page 23.

Note: Some seal manufacturers such as Garlock and Flowserve provide bearing isolators with AEGIS® Rings installed inside.

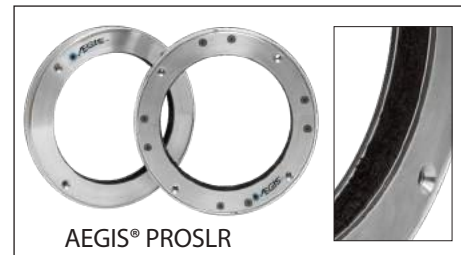

Bolt-through installation into:

- End Bracket
- Custom Bracket



Do not use non-conductive thread-lock

Drill/tap holes per AEGIS® Ring drawing location

- Flat head cap screws
- Socket head cap screws/lock washer



Use EP2400 Conductive Epoxy if thread lock is needed to secure the screws in place.



Epoxy Mounting – External

Motor end bracket must be clean & free of any coatings, paint, or other nonconductive material where AEGIS® SGR will be mounted using conductive epoxy. This is the discharge path to ground therefore metal to metal contact is essential.

Curing can be achieved in 4 hours at or above 24° C. For faster curing times, maximum conductivity and adhesion, heat the bond to between 66°-121° C for 10 minutes and allow to cool.

Pot-life is approximately 10 minutes at 24° C.

AEGIS® Conductive Epoxy was specially developed and tested to stringent vibration and pull test requirements to ensure a strong and reliable long term adhesive bond.



Do not use a substitute epoxy as only the AEGIS® EP2400 has been tested and approved for AEGIS® ring installation.

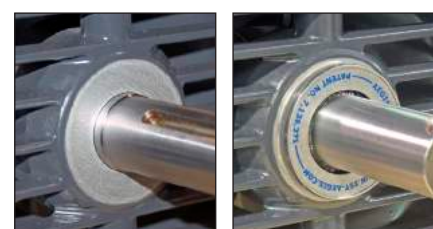

Shaft Preparation for Internal and External Installation

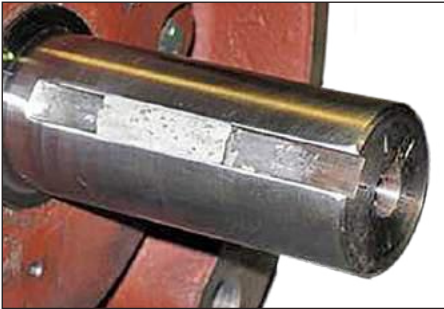

AEGIS® Rings should not operate over a keyway because the edges are very sharp. For proper performance:

Adjust or change spacer and screw lengths to avoid the keyway; or

Fill the keyway (in the area where the AEGIS® microfibers will be in contact with the shaft) with a fast-curing epoxy putty such as Devcon® Plastic Steel® 5 Minute® Putty(SF).

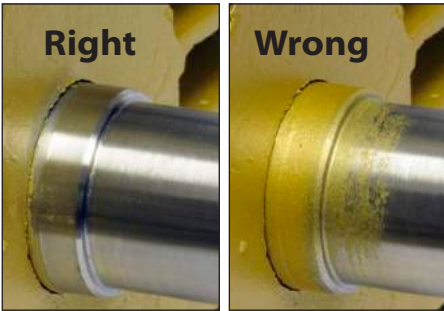

Motor shaft must be conductive:

Shaft must be clean and free of any coatings, paint, or other nonconductive material (clean to bare metal). Depending on the condition of the shaft, it may require using emery cloth or Scotch-Brite™. If the shaft is visibly clean, a non petroleum based solvent may be used to remove any residue. If possible, check the conductivity of the shaft using an ohm meter.



Ohms test:

Place the positive and negative meter leads on the shaft at a place where the microfibers will contact the shaft. Each motor will have a different reading but in general you should have a maximum reading of less than 2 ohms. If the reading is higher, clean the shaft again and retest.

Colloidal Silver Shaft Coating (CS015) is recommended for all applications (we do not recommend any substitutions). The silver enhances the conductivity of the shaft and also lessens the amount of corrosion that can impede the grounding path.

Treating the shaft of the motor prior to installing the AEGIS® Ring:

1. Shaft must be clean and free of any coatings, paint, or other nonconductive material. The shaft must be clean to bare metal.
2. If possible, gently warm the shaft where the AEGIS® CS015 will be applied. This helps the CS015 cure faster. Allow CS015 to come to room temperature prior to opening.
3. Apply a thin, uniform coat of the AEGIS® Colloidal Silver Shaft Coating to the area where the AEGIS® microfibers will be in contact with the motor shaft. Apply all around the shaft. Wait for the first coat to dry to a tack free surface. Drying can be accelerated with the use of gentle heat from a heat gun, but don't exceed 93°C while curing.
4. Apply a 2nd thin, uniform coat of CS015.
5. Allow CS015 to dry to a tack free surface before installing the AEGIS® Ring.
6. Allow the CS015 to cure completely before running the motor. The coating will cure at room temperature in 16-20 hours or in about 60 minutes at 93°C.



Follow all safety precautions. GHS SDS for CS015 available for download at www.est-aegis.com



Colloidal Silver Shaft Coating
PN# CS015



Shaft Preparation continued

Install the AEGIS® SGR so that the aluminum frame maintains an even clearance around the shaft. AEGIS® conductive microfibers must be in contact with conductive metal surface of the shaft.



Do not use thread lock to secure the mounting screws as it may compromise the conductive path to ground.



If thread lock is required, use a small amount of EP2400 AEGIS® Conductive Epoxy to secure the screws in place.

After installation, test for electrical continuity using an Ohm meter. Place one probe on metal frame of AEGIS® SGR and one probe on motor frame.



Motor must be grounded to common earth ground with drive according to applicable standards.

Where AEGIS® SGR is exposed to excessive debris, additional protection of the AEGIS® SGR fibers may be necessary.

Install an O-ring or V-slinger against the ring.

For medium voltage and higher power motors in severe duty environments, the AEGIS® PRO SLR incorporates two specially customized O-rings to protect fibers from excessive dirt and grease.

For custom applications, contact AEGIS® Customer Service/Engineering for assistance.



BEARING CURRENTS

MOTOR GROUNDING

AEGIS® TECHNOLOGY

LOW VOLTAGE MOTORS

MED VOLTAGE MOTORS

DC MOTORS

INSTALL SHAFT PREP

SHAFT VOLTAGE TESTING

SELECT CORRECT SIZE

PARTS LIST

ENGINEERING SPEC



Shaft Voltage Testing - Measuring Shaft Voltages



Shaft Voltage Test Report: Measuring the shaft voltage on VFD driven motors provides the user with valuable information to determine if there is a potential risk of bearing damage from electrical bearing discharges. Surveying and documenting shaft voltage readings and waveforms will assist in determining the appropriate mitigation or solution.

Note: The best time for shaft voltage measurements is during initial start-up in new or repaired motors operated by the VFD. Shaft voltage measurements should be incorporated into preventive and predictive maintenance programs and may be combined with vibration analysis, thermography or other services.

Report template available at: www.est-aegis.com/bearing



AEGIS-OSC-9100MB-W2

Recommended Testing Equipment:

AEGIS® Shaft Voltage Tester™ 100 MHz Digital Oscilloscope with a 10:1 Shaft Voltage Probe™ kit. We recommend a minimum 100MHz bandwidth to accurately measure the high frequency transitions associated with bearing discharge and VFD waveforms.

Recommended Product: PN: AEGIS-OSC-9100MB-W2

- Two 1X/10X probes, one with Shaft Voltage Probe™ SVP Tip attached
- 1000V CAT III multimeter test leads
- AEGIS® One-Touch™ instant image capture feature
- USB flash drive for waveform recording
- 5 hour+ rechargeable/replaceable Li battery
- Carrying case

AEGIS® SVP Shaft Voltage Probe™

The AEGIS® SVP Shaft Voltage Probe™ tip attaches to an oscilloscope voltage probe to easily and accurately measure the voltage on a rotating shaft. The high density of conductive microfibers ensures continuous contact with the rotating shaft. The SVP-KIT-9100MB includes replacement tips, extender rods, a magnetic base/probe holder and AEGIS® Ring simulator.

Caution: Use appropriate safety procedures near rotating equipment.



PN: SVP-KIT-9100MB



Examples of Shaft Voltage Readings

High Peak to Peak common mode voltage –

Typically 20 to 120 volts peak to peak (10 to 60 volts peak). The waveform image shows the capacitive coupled common mode voltage on the shaft of the motor. The “six-step” wave form is the result of the 3 phases of pulses from the VFD. The timing of the pulse width modulation (PWM) pulses to the motor from the drive determines what the waveform looks like. Sometimes it will look like a square wave.

This six-step or square wave is what is seen when there is no bearing discharge and the peak to peak shaft voltage is at its maximum level. The voltage level may eventually overcome the dielectric in non-isolated bearings and begin discharging.

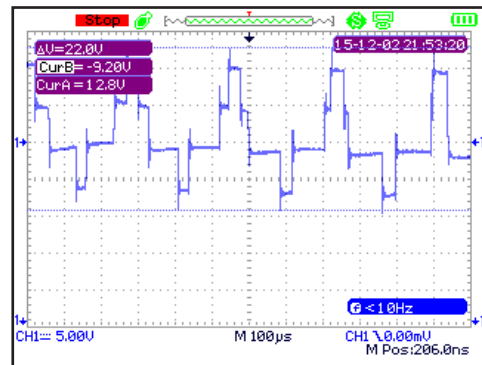

High amplitude EDM discharge pattern –

Typically EDM discharges can occur from 20 to 80 volts peak to peak (10 to 40 volts peak) depending on the motor, the type of bearing, the age of the bearing, and other factors. The waveform image shows an increase in voltage on the shaft and then a sharp vertical line indicating a voltage discharge. This can occur thousands of times in a second, based on the carrier frequency of the drive. The sharp vertical discharge at the trailing edge of the voltage is an ultra high frequency dv/dt with a typical “discharge frequency” of 1 to 125 MHz (based on testing results in many applications).

Reference: NEMA MG1 Section 31.4.4.3

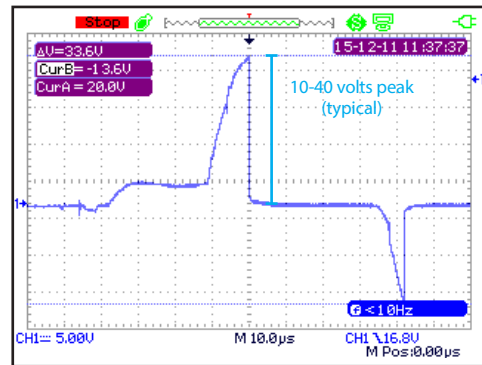

Low amplitude voltage discharge pattern –

Typically the voltages are 4 to 15 volts peak to peak (2 to 8 volts peak). The waveform image shows a more continuous discharge pattern with lower dv/dt frequencies. The lower voltage may be due to greater current flow in the bearings which is the result of the bearing lubrication becoming conductive or could be a function of the motor’s drive, speed, loading or other factors. As discharges occur in the bearings, the lubrication is contaminated with carbon and metal particles. The lower impedance to the shaft voltages results in lower peak to peak voltages. This condition is usually found in motors that have been in operation for many months or years.

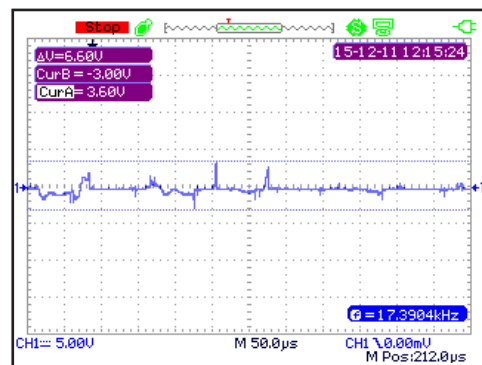

Peak to Peak voltage with AEGIS® ring installed –

With the AEGIS® ring installed, a bare steel shaft will typically show shaft voltages of 2 to 10 volts peak to peak (1 to 5 volts peak) depending on the power of the motor, ground noise, the conductivity of the shaft and other factors. The voltage readings may be decreased further with the application of AEGIS® Colloidal Silver Shaft Coating which allows for higher shaft surface conductivity and a more efficient electron transfer to the conductive micro fiber tips.

The waveform image shows the low peak to peak waveform of a motor with the AEGIS® SGR ring installed and discharging the shaft voltages normally.

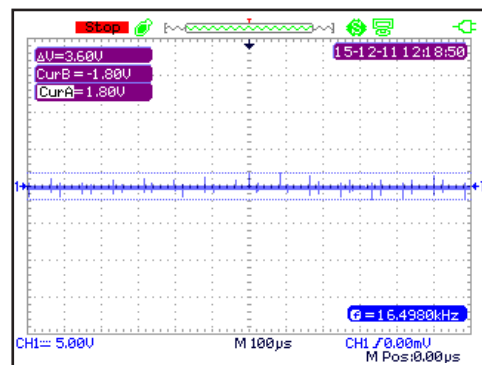

BEARING CURRENTS

MOTOR GROUNDING

AEGIS® TECHNOLOGY

LOW VOLTAGE MOTORS

MED VOLTAGE MOTORS

DC MOTORS

INSTALL SHAFT PREP

SHAFT VOLTAGE TESTING

SELECT CORRECT SIZE

PARTS LIST

ENGINEERING SPEC



AEGIS-OSC-9100 Setup and Parameters



The following pages describe the settings and parameters we use to capture shaft voltages. For ease of use, the factory settings are preset for shaft voltage measurements.

To demonstrate, we will use the AEGIS-OSC-9100 Shaft Voltage Tester™ - a 2 channel - 100 MHz Digital Oscilloscope designed to easily capture shaft voltage measurements on operating equipment. Refer to your owner's manual or quick start for detailed instructions and explanations of other advanced functions.

The AEGIS® Shaft Voltage Tester™ may be reset to factory settings at any time using the procedure below.

Setup: AEGIS® SVP Tip Installation

AEGIS® Meter Probe PP510 10:1 probe

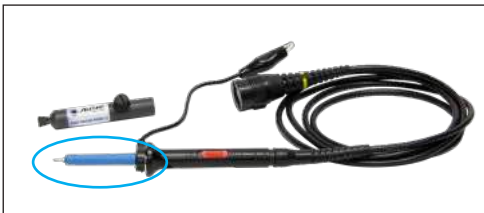

1. The AEGIS® Meter probe has an insulated sleeve over the tip. Do not remove this cover.

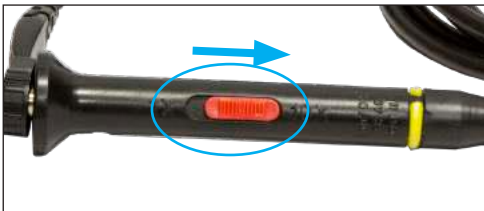

2. Set the probe to 10X.



3. Secure the AEGIS® probe tip using the thumb screw. Be careful not to over-tighten.



4. Connect 10:1 probe into Ch 1.

Note: The AEGIS® meter comes with one SVP probe tip already installed

Setup: Factory Settings / Reset



1. Press **SAVE/RECALL**
2. **F1 TYPE**. Choose **FACTORY**. Press **▶**
3. **F5 LOAD**

Default parameters included:

- DC Coupling
- Waveform Sampling
- Peak to Peak Voltage (Vpp) displayed on Measure screen

For the full list of factory settings, see the user manual included on the flash drive or online.

www.est-aegis.com/tester-manual



Setup: Select 10X Probe



Press **CH1** to bring up the CH1 menu on Page 1/3. (If a different page pops up, press **F5** to cycle back to Page 1/3). Press **F4 Probe**



Select **10X** with the blue up and down arrows and press **ENTER**. Press **MENU** to exit the **CH1** menu.

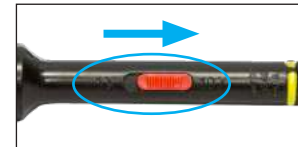

Be sure probe is set to 10X.

Setup: Calibrating the Probe



Now the scope is set up to calibrate the probe. The AEGIS-OSC-9100 includes a two-pronged calibration dongle that plugs into the side of the scope. This micro-USB dongle generates a square wave used to fine-tune the probe.

Calibration must be done the first time a new probe is used, and should be checked periodically to ensure accurate waveform measurements.



Adjustment screw

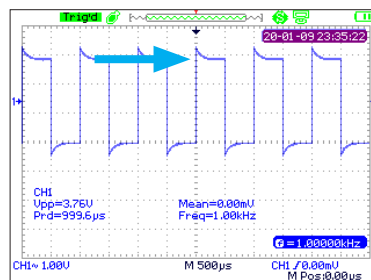

Press **AUTO**. The scope will display a train of approximately square waves of amplitude 3V and frequency 1 kHz.

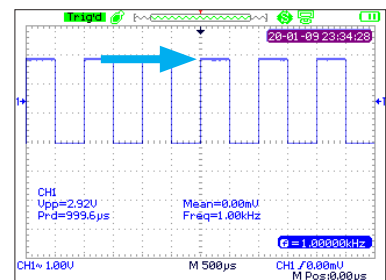

Using the included screwdriver with insulated handle, adjust the screw in the probe until the waves are displayed with square edges. The probe is now calibrated.

Remove dongle.



Menu Button

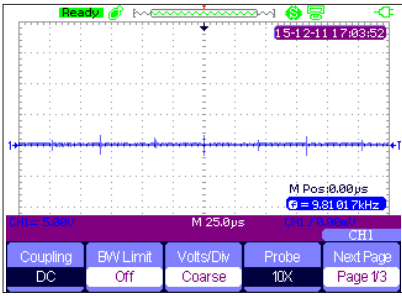

Here is the CH1 menu. Pressing **MENU** collapses it.

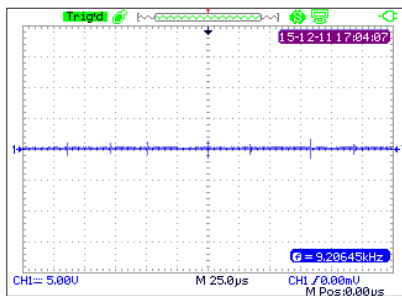

Pressing **MENU** again opens it back up.

The **MENU** button opens and closes the last menu viewed.

Auto Button

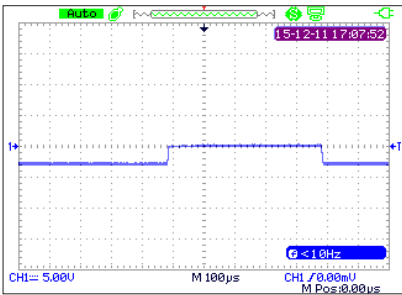

When viewing a waveform, pressing **AUTO** resizes the voltage and time scales to fit the waveform...

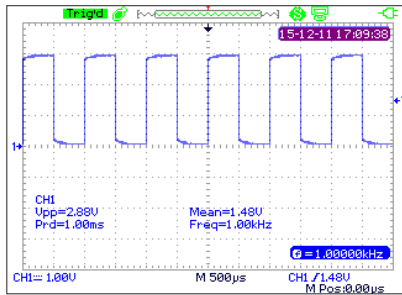

...and displays Vpp, right onscreen. This will remain until a menu is brought up.

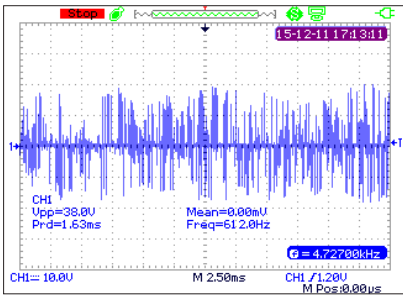

Caution: Shaft voltages are highly random so using **AUTO** mode may give too large a timescale. This can be adjusted. See Setting Time Period (page 39).

Note: Noise from the VFD may also cause CH2 to be displayed - even if no probe is plugged into the CH2 BNC. If this occurs, press **CH2** until the red trace disappears, and find Vpp using **Measure** or **Cursors** (page 41).

Run/Stop Button



While making measurements, **RUN/STOP** freezes the screen. When stopped, the word **STOP** will appear in the upper left of the screen.

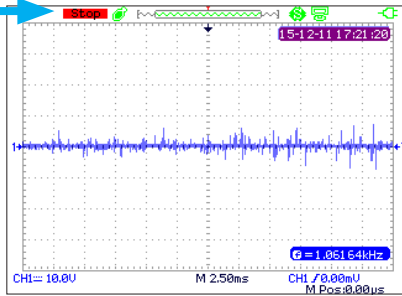

This enables you to analyze the waveform more easily and save if desired.

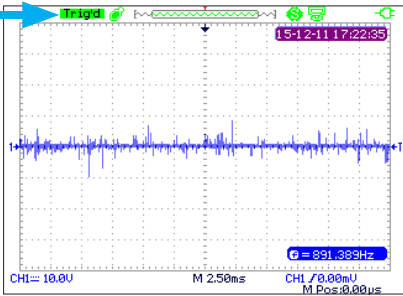

Pressing **RUN/STOP** again resumes measurement. Stop will change to Trig'd or Auto.



Setting Voltage Amplitude



An EDM discharge pattern will show a climb in voltage and then a sharp vertical line. The sharp vertical line shows the moment of discharge to ground. To get a good image of a discharge, you may need to adjust the display scale.

Control the vertical scale of the displayed signal by adjusting the volts per division. The entire signal, from peak to peak, should all be displayed on the screen. 5V is a good place to start, and then adjust up or down based on the conditions. The setting selected in volts per division is shown in the lower left of the screen.

Press “V” to decrease vertical sensitivity (shorter waveforms)

Press “mV” to increase vertical sensitivity (taller waveforms)

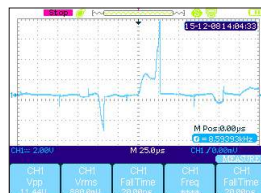

Amplitude will need to be adjusted according to the conditions. Set to show complete wave from top peak to bottom peak using the scale buttons.

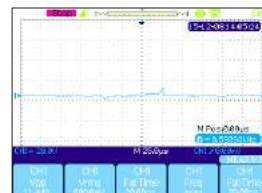

In this example the amplitude is too small. Increase the range (mV) to show more detail.

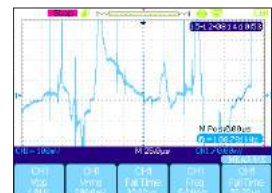

In this example the amplitude is too large. Decrease the range (V) to show top and bottom peaks.

Setting Time Period



Control the horizontal scale of the displayed signal by adjusting the time scale. 500µs (microseconds) is a good place to start and then adjust the time based on the conditions. The selected seconds per division setting is shown at the bottom center of the screen. The EDM wave forms are best displayed at a setting of 50us/div or less. Adjust the time setting to show the desired waveform.

Press “ns” to increase horizontal sensitivity (wider waveforms)

Press “s” to decrease horizontal sensitivity (narrower waveforms)



This is an example of a Time period set to 25 microseconds (25/1,000,000). It clearly shows a climb in voltage and a sharp discharge to ground.

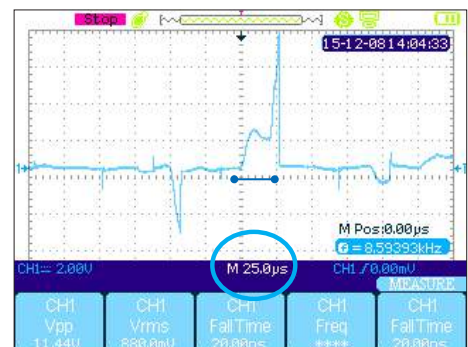

Adjusting Waveform Position

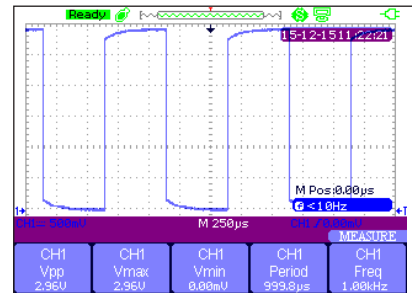
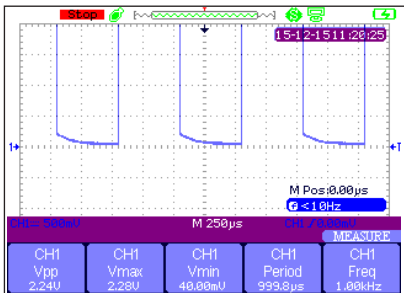

Some waveforms may display too high or low on the screen. This often happens when using the **MEASURE** window (described on page 41).

Waveforms' onscreen position can be adjusted by offsetting the voltage.

The up arrow moves the waveform higher onscreen & the down arrow moves it lower. The current offset level is indicated by the blue 1 and arrow at the extreme left of the screen.

The time can also be offset. The arrows under similarly move waveforms left and right.

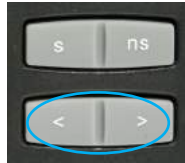

AEGIS® One-Touch™ Screen Capture Feature Saving Images as .BMP on USB

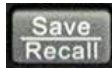

1. Plug in a USB drive – you will get a screen message “USB Flash Drive Plugged In!”
2. Hold the **SAVE/RECALL** button in for approximately six seconds until progress bar  appears near the bottom of the screen. 
3. When finished saving images, simply remove the USB Flash drive and view .BMP on computer

Screen capture may be done either during a “live view” or when the screen is paused:

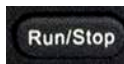
1. Press **RUN/STOP** to pause the screen. Voltage & time scales can be changed while screen is stopped. 
2. When the bars have disappeared, press **RUN/STOP** to resume live view.



Peak to Peak Voltage (Vpp) with Measure

The AEGIS-OSC-9100 offers three methods to measure peak to peak voltage (Vpp): **Measure**, and **Cursor**, and **Auto**. **Auto** was described in the Auto Button section (page 38).

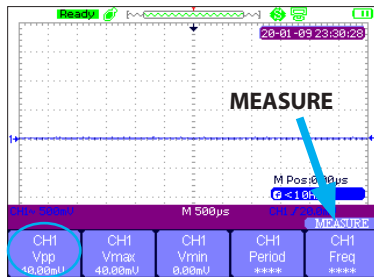

Press **CURSOR|MEASURE** until the **MEASURE** menu appears. If Vpp is listed above F1, skip the rest of this section.

Otherwise, press **F1** to continue set up.

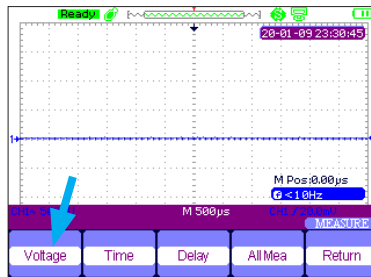

Press **F1 VOLTAGE**

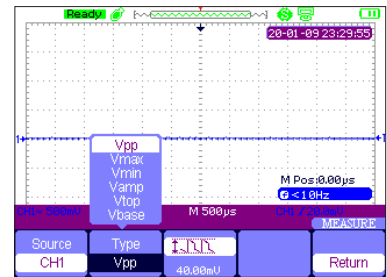

Press **F2 TYPE**. Choose **Vpp**, then press **F5 RETURN**

Peak to Peak Voltage with Cursors

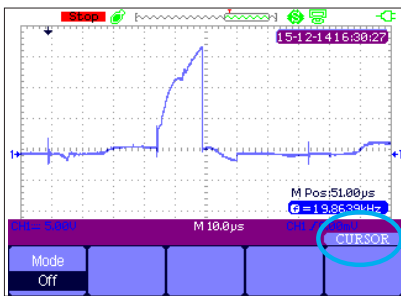

Press **CURSOR|MEASURE** until the **CURSOR** menu appears.

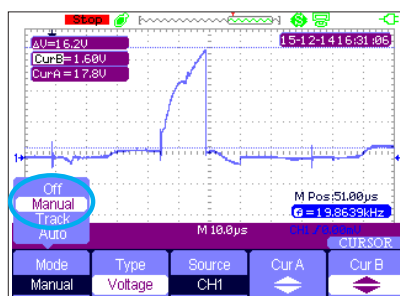

Press **F1 MODE**, select **Manual**, and press **F2**

Note: If **TIME** displays over **F2**, press **F2** until it changes to **VOLTAGE**.

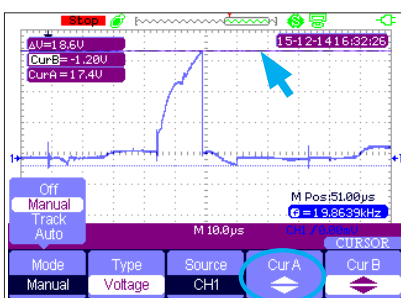

Press **F4 CurA** and use the blue **▲** & **▼** to move the upper cursor (emphasized above) to the top of discharge to be measured.

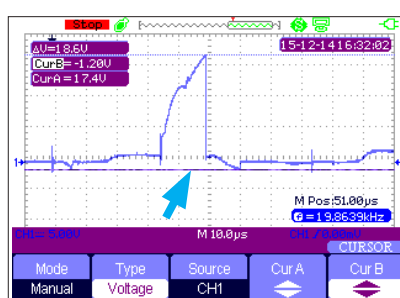

Press **F5 CurB** and use **▲** & **▼** to move the cursor to the bottom of the discharge to be measured.

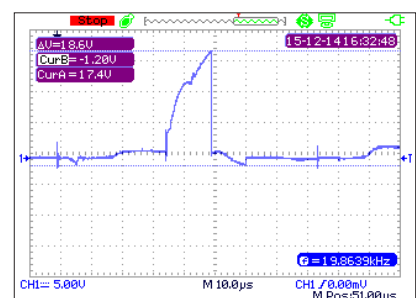

ΔV is the peak voltage of the discharge. For a better view, press **MENU** to collapse the cursor menu.



Taking the Measurements- EMI

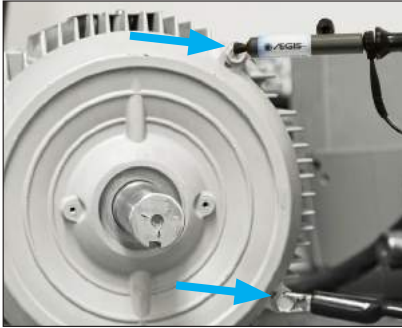

Ground Reference Reading: EMI

1. The reading displays ground noise or EMI being produced by the motor/drive system. This electrical noise may be present before and after installing the AEGIS® ring.
2. Find 2 ground points on the motor. Must be bare metal and conductive.
3. Place the SVP on one of the points and the probe grounding clip on the other point.
4. Measurements will vary depending on the motor size and conditions.

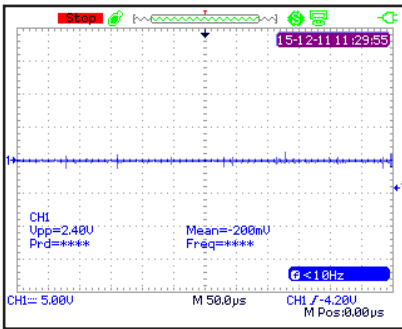

Taking the Measurements- Shaft Voltage

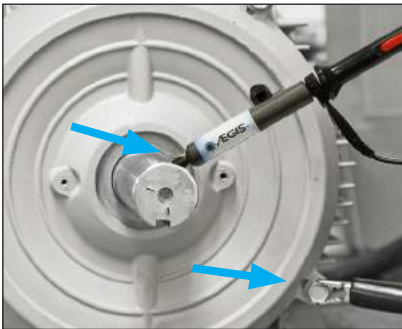

Shaft Voltage Reading

1. Shaft must be clean & free of any coatings, paint or other nonconductive material.
2. Secure the probe in place with magnetic base.
3. Align AEGIS® SVP on shaft end or side ensuring continuous contact. Avoid keyway if possible.
4. Place oscilloscope grounding lead on bare metal of motor ensuring conductive path to ground.
5. If this test is to be used in a report, save an image to a USB drive.

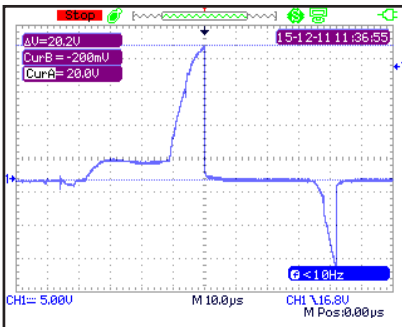

Follow all safety precaution when working with rotating equipment.



Measurements Using the AEGIS® Grounding Simulator™

The AEGIS® Grounding Simulator™ can be used to simulate how the shaft voltages will change after an AEGIS® Ring is installed. It is a quick way of showing a “Before & After” but since only a small amount of conductive microfibers are touching the shaft the shaft voltage may be higher than when the circumferential AEGIS® Ring is installed.

1. Take the Shaft Voltage Reading without Shaft Grounding
2. Take the Shaft Voltage Reading with the AEGIS® Grounding Simulator™

First Take the Shaft Voltage Reading without Shaft Grounding

1. Shaft must be clean & free of any coatings, paint or other nonconductive material.
2. Secure the probe in place with magnetic base.
3. Align AEGIS® SVP™ on shaft end or side ensuring continuous contact. Avoid keyway if possible.
4. Place probe grounding lead on bare metal of motor ensuring conductive path to ground.
5. Save the image, as described on page 40.

The voltage measurement of 28,6V peak to peak is an example of the voltage discharging through the bearings without AEGIS® shaft grounding.

 Follow all safety precaution when working with rotating equipment.

Next Take the Shaft Voltage Reading with the Grounding Simulator™ Touching the Shaft

1. Maintain the same setup as above.
2. Place the AEGIS® Grounding Simulator™ grounding lead on bare metal of motor ensuring conductive path to ground.
3. Place the Simulator against the shaft to simulate the AEGIS® Shaft Grounding Ring.
4. Freeze the screen and save the image.

The voltage measurement of 2.2V peak to peak is an example of the voltage discharging through the AEGIS® Grounding Simulator to ground. The AEGIS® Shaft Grounding Ring will perform equally or better.

 Follow all safety precaution when working with rotating equipment.

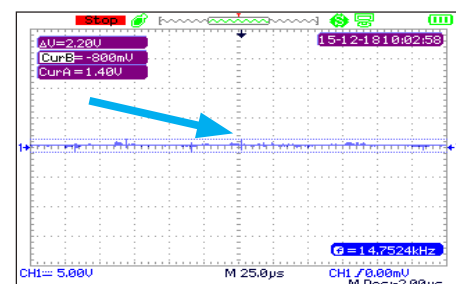
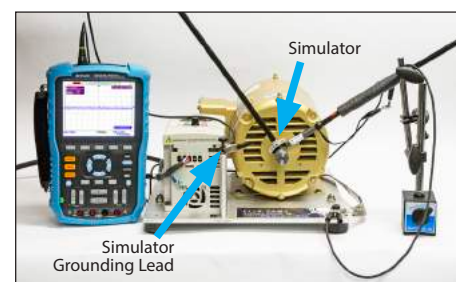
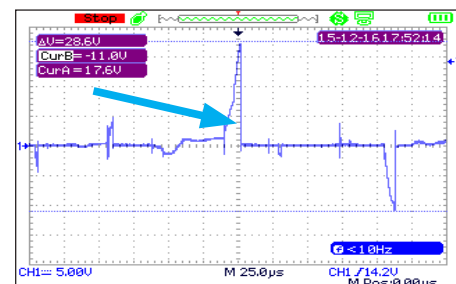
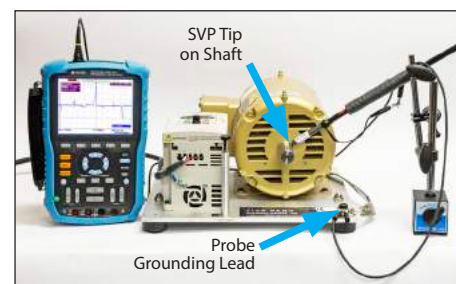

BEARING CURRENTS

MOTOR GROUNDING

AEGIS® TECHNOLOGY

LOW VOLTAGE MOTORS

MED VOLTAGE MOTORS

DC MOTORS

INSTALL SHAFT PREP

SHAFT VOLTAGE TESTING

SELECT CORRECT SIZE

PARTS LIST

ENGINEERING SPEC



Selecting the Correct Size Ring

BEARING CURRENTS

MOTOR GROUNDING

AEGIS® TECHNOLOGY

LOW VOLTAGE MOTORS

MED VOLTAGE MOTORS

DC MOTORS

INSTALL SHAFT PREP

SHAFT VOLTAGE TESTING

SELECT CORRECT SIZE

PARTS LIST

ENGINEERING SPEC



For standard IEC or NEMA frame motors, the AEGIS® uKIT is the best option. It avoids most shaft shoulders and slingers/seals.

AEGIS® uKIT includes 4 different bracket sizes to suit most situations.



Question to ask: Does the motor have a shaft shoulder?

If **YES or NOT SURE**, then the AEGIS® uKIT is the easiest option because it avoids the shaft shoulder area, any slingers/seals or irregular shaped end bracket.

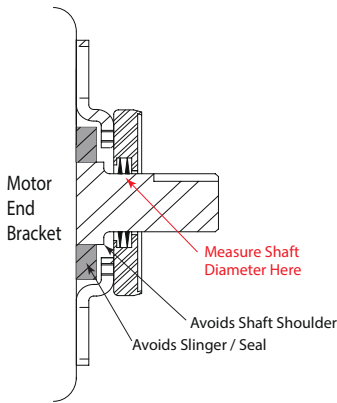

AEGIS® uKIT is attached to motor with screws/washers provided or with conductive epoxy. AEGIS® EP2400 Conductive Epoxy sold separately.

See AEGIS® website for bolt hole circle and installation instructions.

See page 49 for more details.

If **NO**, the ring can be mounted directly to the end bracket using screws or conductive epoxy.

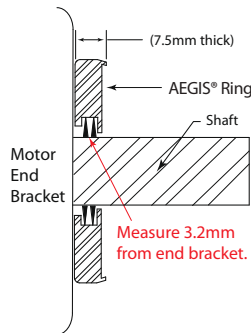

Measure shaft diameter at a point 3,2mm from motor end bracket. Then refer to the parts list to locate the correct part number and mounting option of your choosing.

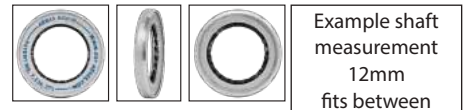

Example shaft measurement 12mm fits between

Solid Ring Catalog Number	Split Ring Catalog Number	Bolt Through Catalog Number	Solid Ring with Conductive Epoxy	Split Ring with Conductive Epoxy	Min. Shaft Diameter	Max. Shaft Diameter
SGR-9.0-2	SGR-9.0-2A4	SGR-9.0-3MFH	SGR-9.0-0AW	SGR-9.0-0A4W	10,1	11,0
SGR-10.1-2	SGR-10.1-2A4	SGR-10.1-3MFH	SGR-10.1-0AW	SGR-10.1-0A4W	11,1	12,2
SGR-11.2-2	SGR-11.2-2A4	SGR-11.2-3MFH	SGR-11.2-0AW	SGR-11.2-0A4W	12,3	13,2

If **YES** and you want to mount the ring to fit the shaft shoulder then you need to measure the length of the shoulder. See note in red below. If still applicable, measure shaft shoulder diameter then refer to parts list (as shown above) to locate the correct SGR part number.

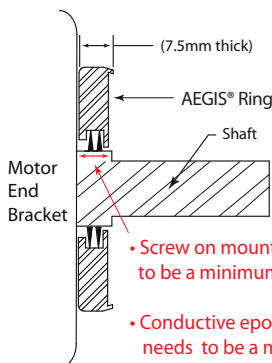

Custom Option for Short Shaft Shoulders: If the shaft shoulder is between 4,76mm and 9,4mm we offer a custom part with fibers closer to the back of the ring. To order this option, add an "X" or "AX" to the suffix of the part.

Example:

Standard SGR
 PN: SGR-6.9-0A4W
 PN: SGR-6.9-0AW
 PN: SGR-6.9-2
 PN: SGR-6.9-2A4
 PN: SGR-6.9-3MFH

Short Shoulder SGR
 PN: SGR-6.9-0A4WX
 PN: SGR-6.9-0AWX
 PN: SGR-6.9-2AX
 PN: SGR-6.9-1A4X
 PN: SGR-6.9-3MFHAX

If the shoulder is less than 4,76mm then refer to the uKIT.



Patented Technology

AEGIS® SGR Shaft Grounding Ring Options

	<p>pg. 46-47</p>	<p>Standard Mounting Clamps (-2) Shaft diameters: 7.9 to 152.9mm 3 to 4 mounting clamps, M3 x .50 x 8mm cap screws and washers Quick and easy installation to most surfaces</p>	<p>BEARING CURRENTS</p>
	<p>pg. 46-47</p>	<p>Split Ring (-2A4) Shaft diameter: 7.9 to 152.9mm 4 to 6 mounting clamps, M3 x .50 x 8mm cap screws and washers Installs without decoupling motor</p>	<p>MOTOR GROUNDING</p>
	<p>pg. 46-47</p>	<p>Bolt Through Mounting (-3MFH) Shaft diameters: 7.9 to 152.9mm M3 x 12mm flat head screws 2 mounting holes up to shaft size 98.9mm 4 mounting holes for larger sizes</p>	<p>AEGIS® TECHNOLOGY</p>
	<p>pg. 46-47</p>	<p>Conductive Epoxy Mounting (-0AW, -0A4W) Shaft diameters: 7.9 to 152.9mm Solid and Split Ring Quick and easy installation to metal motor frame Conductive Epoxy Included</p>	<p>LOW VOLTAGE MOTORS</p>
	<p>pg. 48</p>	<p>Press Fit Mounting (-0A6) Shaft diameters: 7.9 to 152.9mm Clean dry press fit Custom sizes available</p>	<p>MED VOLTAGE MOTORS</p>
	<p>pg. 49</p>	<p>uKIT - SGR with Universal Mounting Bracket Sized for IEC Frame motors Solid and Split Ring Can be mounted with hardware or conductive epoxy</p>	<p>DC MOTORS</p>
	<p>pg. 50-51</p>	<p>AEGIS® PRO Series and WTG 6 rows of conductive microfiber AEGIS® PRO Series AEGIS® WTG for Wind Turbine Generators</p>	<p>INSTALL SHAFT PREP</p>
	<p>pg. 52</p>	<p>AEGIS® Shaft Voltage Tester™ AEGIS® Shaft Voltage Tester™ SVP - AEGIS® Shaft Voltage Probe</p>	<p>SHAFT VOLTAGE TESTING</p>
	<p>pg. 53</p>	<p>Accessories HFGS - High-Frequency Ground Strap CS015 - AEGIS® Colloidal Silver Shaft Coating EP2400 - AEGIS® Conductive Epoxy</p>	<p>SELECT CORRECT SIZE</p>

PARTS LIST

ENGINEERING SPEC



Solid Ring, Split Ring, and Bolt Through Mounting for Low Voltage Motors to 375 kW

Dimensions in mm

	Solid Ring Catalog Number	Split Ring* Catalog Number	Bolt Through Catalog Number	Solid Ring with Conductive Epoxy	Split Ring* with Conductive Epoxy	Min. Shaft Diameter	Max. Shaft Diameter	Outside Diameter	Thickness Max
	SGR-6.9-2	SGR-6.9-2A4	SGR-6.9-3MFH	SGR-6.9-0AW	SGR-6.9-0A4W	7,9	9,0	40,6	7,5
	SGR-8.0-2	SGR-8.0-2A4	SGR-8.0-3MFH	SGR-8.0-0AW	SGR-8.0-0A4W	9,1	10,0	40,6	7,5
	SGR-9.0-2	SGR-9.0-2A4	SGR-9.0-3MFH	SGR-9.0-0AW	SGR-9.0-0A4W	10,1	11,0	40,6	7,5
	SGR-10.1-2	SGR-10.1-2A4	SGR-10.1-3MFH	SGR-10.1-0AW	SGR-10.1-0A4W	11,1	12,2	40,6	7,5
	SGR-11.2-2	SGR-11.2-2A4	SGR-11.2-3MFH	SGR-11.2-0AW	SGR-11.2-0A4W	12,3	13,2	40,6	7,5
	SGR-12.2-2	SGR-12.2-2A4	SGR-12.2-3MFH	SGR-12.2-0AW	SGR-12.2-0A4W	13,3	14,2	40,6	7,5
	SGR-13.2-2	SGR-13.2-2A4	SGR-13.2-3MFH	SGR-13.2-0AW	SGR-13.2-0A4W	14,3	15,4	40,6	7,5
	SGR-14.4-2	SGR-14.4-2A4	SGR-14.4-3MFH	SGR-14.4-0AW	SGR-14.4-0A4W	15,5	16,4	40,6	7,5
	SGR-15.4-2	SGR-15.4-2A4	SGR-15.4-3MFH	SGR-15.4-0AW	SGR-15.4-0A4W	16,5	17,4	53,3	7,5
	SGR-16.4-2	SGR-16.4-2A4	SGR-16.4-3MFH	SGR-16.4-0AW	SGR-16.4-0A4W	17,5	18,5	53,3	7,5
	SGR-17.6-2	SGR-17.6-2A4	SGR-17.6-3MFH	SGR-17.6-0AW	SGR-17.6-0A4W	18,6	19,7	53,3	7,5
	SGR-18.7-2	SGR-18.7-2A4	SGR-18.7-3MFH	SGR-18.7-0AW	SGR-18.7-0A4W	19,8	20,7	53,3	7,5
	SGR-19.7-2	SGR-19.7-2A4	SGR-19.7-3MFH	SGR-19.7-0AW	SGR-19.7-0A4W	20,8	21,7	53,3	7,5
	SGR-20.7-2	SGR-20.7-2A4	SGR-20.7-3MFH	SGR-20.7-0AW	SGR-20.7-0A4W	21,8	22,7	53,3	7,5
	SGR-21.7-2	SGR-21.7-2A4	SGR-21.7-3MFH	SGR-21.7-0AW	SGR-21.7-0A4W	22,8	23,7	53,3	7,5
	SGR-22.8-2	SGR-22.8-2A4	SGR-22.8-3MFH	SGR-22.8-0AW	SGR-22.8-0A4W	23,8	24,9	53,3	7,5
	SGR-23.9-2	SGR-23.9-2A4	SGR-23.9-3MFH	SGR-23.9-0AW	SGR-23.9-0A4W	25,0	25,9	53,3	7,5
	SGR-24.9-2	SGR-24.9-2A4	SGR-24.9-3MFH	SGR-24.9-0AW	SGR-24.9-0A4W	26,0	26,9	53,3	7,5
	SGR-25.9-2	SGR-25.9-2A4	SGR-25.9-3MFH	SGR-25.9-0AW	SGR-25.9-0A4W	27,0	28,1	53,3	7,5
	SGR-27.1-2	SGR-27.1-2A4	SGR-27.1-3MFH	SGR-27.1-0AW	SGR-27.1-0A4W	28,2	29,1	53,3	7,5
	SGR-28.1-2	SGR-28.1-2A4	SGR-28.1-3MFH	SGR-28.1-0AW	SGR-28.1-0A4W	29,2	30,1	53,3	7,5
	SGR-29.1-2	SGR-29.1-2A4	SGR-29.1-3MFH	SGR-29.1-0AW	SGR-29.1-0A4W	30,2	31,2	53,3	7,5
	SGR-30.3-2	SGR-30.3-2A4	SGR-30.3-3MFH	SGR-30.3-0AW	SGR-30.3-0A4W	31,3	32,3	53,3	7,5
	SGR-31.3-2	SGR-31.3-2A4	SGR-31.3-3MFH	SGR-31.3-0AW	SGR-31.3-0A4W	32,4	33,3	53,3	7,5
	SGR-32.3-2	SGR-32.3-2A4	SGR-32.3-3MFH	SGR-32.3-0AW	SGR-32.3-0A4W	33,4	34,4	53,3	7,5
	SGR-33.4-2	SGR-33.4-2A4	SGR-33.4-3MFH	SGR-33.4-0AW	SGR-33.4-0A4W	34,5	35,4	53,3	7,5
	SGR-34.4-2	SGR-34.4-2A4	SGR-34.4-3MFH	SGR-34.4-0AW	SGR-34.4-0A4W	35,5	36,4	68,1	7,5
	SGR-35.5-2	SGR-35.5-2A4	SGR-35.5-3MFH	SGR-35.5-0AW	SGR-35.5-0A4W	36,5	37,6	68,1	7,5
	SGR-36.6-2	SGR-36.6-2A4	SGR-36.6-3MFH	SGR-36.6-0AW	SGR-36.6-0A4W	37,7	38,6	68,1	7,5
	SGR-37.6-2	SGR-37.6-2A4	SGR-37.6-3MFH	SGR-37.6-0AW	SGR-37.6-0A4W	38,7	39,6	68,1	7,5
	SGR-38.6-2	SGR-38.6-2A4	SGR-38.6-3MFH	SGR-38.6-0AW	SGR-38.6-0A4W	39,7	40,8	68,1	7,5
	SGR-39.8-2	SGR-39.8-2A4	SGR-39.8-3MFH	SGR-39.8-0AW	SGR-39.8-0A4W	40,9	41,8	68,1	7,5
	SGR-40.8-2	SGR-40.8-2A4	SGR-40.8-3MFH	SGR-40.8-0AW	SGR-40.8-0A4W	41,9	42,8	68,1	7,5
	SGR-41.8-2	SGR-41.8-2A4	SGR-41.8-3MFH	SGR-41.8-0AW	SGR-41.8-0A4W	42,9	43,9	68,1	7,5
	SGR-43.0-2	SGR-43.0-2A4	SGR-43.0-3MFH	SGR-43.0-0AW	SGR-43.0-0A4W	44,0	45,0	68,1	7,5
	SGR-44.0-2	SGR-44.0-2A4	SGR-44.0-3MFH	SGR-44.0-0AW	SGR-44.0-0A4W	45,1	46,0	68,1	7,5
	SGR-45.0-2	SGR-45.0-2A4	SGR-45.0-3MFH	SGR-45.0-0AW	SGR-45.0-0A4W	46,1	47,1	68,1	7,5
	SGR-46.1-2	SGR-46.1-2A4	SGR-46.1-3MFH	SGR-46.1-0AW	SGR-46.1-0A4W	47,2	48,1	68,1	7,5
	SGR-47.1-2	SGR-47.1-2A4	SGR-47.1-3MFH	SGR-47.1-0AW	SGR-47.1-0A4W	48,2	49,1	68,1	7,5
	SGR-48.2-2	SGR-48.2-2A4	SGR-48.2-3MFH	SGR-48.2-0AW	SGR-48.2-0A4W	49,2	50,3	68,1	7,5
	SGR-49.3-2	SGR-49.3-2A4	SGR-49.3-3MFH	SGR-49.3-0AW	SGR-49.3-0A4W	50,4	51,3	68,1	7,5
	SGR-50.3-2	SGR-50.3-2A4	SGR-50.3-3MFH	SGR-50.3-0AW	SGR-50.3-0A4W	51,4	52,3	78,7	7,5
	SGR-51.3-2	SGR-51.3-2A4	SGR-51.3-3MFH	SGR-51.3-0AW	SGR-51.3-0A4W	52,4	53,5	78,7	7,5
	SGR-52.5-2	SGR-52.5-2A4	SGR-52.5-3MFH	SGR-52.5-0AW	SGR-52.5-0A4W	53,6	54,5	78,7	7,5
	SGR-53.5-2	SGR-53.5-2A4	SGR-53.5-3MFH	SGR-53.5-0AW	SGR-53.5-0A4W	54,6	55,5	78,7	7,5
	SGR-54.5-2	SGR-54.5-2A4	SGR-54.5-3MFH	SGR-54.5-0AW	SGR-54.5-0A4W	55,6	56,6	78,7	7,5
	SGR-55.7-2	SGR-55.7-2A4	SGR-55.7-3MFH	SGR-55.7-0AW	SGR-55.7-0A4W	56,7	57,7	78,7	7,5
	SGR-56.7-2	SGR-56.7-2A4	SGR-56.7-3MFH	SGR-56.7-0AW	SGR-56.7-0A4W	57,8	58,7	78,7	7,5
	SGR-57.7-2	SGR-57.7-2A4	SGR-57.7-3MFH	SGR-57.7-0AW	SGR-57.7-0A4W	58,8	59,8	78,7	7,5
	SGR-58.8-2	SGR-58.8-2A4	SGR-58.8-3MFH	SGR-58.8-0AW	SGR-58.8-0A4W	59,9	60,8	78,7	7,5
	SGR-59.8-2	SGR-59.8-2A4	SGR-59.8-3MFH	SGR-59.8-0AW	SGR-59.8-0A4W	60,9	61,8	91,4	7,5
	SGR-60.9-2	SGR-60.9-2A4	SGR-60.9-3MFH	SGR-60.9-0AW	SGR-60.9-0A4W	61,9	63,0	91,4	7,5
	SGR-62.0-2	SGR-62.0-2A4	SGR-62.0-3MFH	SGR-62.0-0AW	SGR-62.0-0A4W	63,1	64,0	91,4	7,5
	SGR-63.0-2	SGR-63.0-2A4	SGR-63.0-3MFH	SGR-63.0-0AW	SGR-63.0-0A4W	64,1	65,0	91,4	7,5
	SGR-64.0-2	SGR-64.0-2A4	SGR-64.0-3MFH	SGR-64.0-0AW	SGR-64.0-0A4W	65,1	66,2	91,4	7,5
	SGR-65.2-2	SGR-65.2-2A4	SGR-65.2-3MFH	SGR-65.2-0AW	SGR-65.2-0A4W	66,3	67,2	91,4	7,5
	SGR-66.2-2	SGR-66.2-2A4	SGR-66.2-3MFH	SGR-66.2-0AW	SGR-66.2-0A4W	67,3	68,2	91,4	7,5
	SGR-67.2-2	SGR-67.2-2A4	SGR-67.2-3MFH	SGR-67.2-0AW	SGR-67.2-0A4W	68,3	69,3	91,4	7,5
	SGR-68.4-2	SGR-68.4-2A4	SGR-68.4-3MFH	SGR-68.4-0AW	SGR-68.4-0A4W	69,4	70,4	91,4	7,5
	SGR-69.4-2	SGR-69.4-2A4	SGR-69.4-3MFH	SGR-69.4-0AW	SGR-69.4-0A4W	70,5	71,4	91,4	7,5
	SGR-70.4-2	SGR-70.4-2A4	SGR-70.4-3MFH	SGR-70.4-0AW	SGR-70.4-0A4W	71,5	72,5	91,4	7,5
	SGR-71.5-2	SGR-71.5-2A4	SGR-71.5-3MFH	SGR-71.5-0AW	SGR-71.5-0A4W	72,6	73,5	91,4	7,5
	SGR-72.5-2	SGR-72.5-2A4	SGR-72.5-3MFH	SGR-72.5-0AW	SGR-72.5-0A4W	73,6	74,5	104,1	7,5
	SGR-73.6-2	SGR-73.6-2A4	SGR-73.6-3MFH	SGR-73.6-0AW	SGR-73.6-0A4W	74,6	75,7	104,1	7,5
	SGR-74.7-2	SGR-74.7-2A4	SGR-74.7-3MFH	SGR-74.7-0AW	SGR-74.7-0A4W	75,8	76,7	104,1	7,5
	SGR-75.7-2	SGR-75.7-2A4	SGR-75.7-3MFH	SGR-75.7-0AW	SGR-75.7-0A4W	76,8	77,7	104,1	7,5
	SGR-76.7-2	SGR-76.7-2A4	SGR-76.7-3MFH	SGR-76.7-0AW	SGR-76.7-0A4W	77,8	78,9	104,1	7,5
	SGR-77.9-2	SGR-77.9-2A4	SGR-77.9-3MFH	SGR-77.9-0AW	SGR-77.9-0A4W	79,0	79,9	104,1	7,5
	SGR-78.9-2	SGR-78.9-2A4	SGR-78.9-3MFH	SGR-78.9-0AW	SGR-78.9-0A4W	80,0	80,9	104,1	7,5

*Custom Part-No Return

*Custom Part-No Return



Patented Technology

Note: Use PRO Series Rings for Low Voltage Motors Greater than 375 kW and All Medium Voltage Motors

See page 22

Solid Ring Catalog Number	Split Ring* Catalog Number	Bolt Through Catalog Number	Solid Ring with Conductive Epoxy	Split Ring* with Conductive Epoxy	Min. Shaft Diameter	Max. Shaft Diameter	Outside Diameter	Thickness Max
SGR-79.9-2	SGR-79.9-2A4	SGR-79.9-3MFH	SGR-79.9-0AW	SGR-79.9-0A4W	81,0	82,0	104,1	7,5
SGR-81.1-2	SGR-81.1-2A4	SGR-81.1-3MFH	SGR-81.1-0AW	SGR-81.1-0A4W	82,1	83,1	104,1	7,5
SGR-82.1-2	SGR-82.1-2A4	SGR-82.1-3MFH	SGR-82.1-0AW	SGR-82.1-0A4W	83,2	84,1	104,1	7,5
SGR-83.1-2	SGR-83.1-2A4	SGR-83.1-3MFH	SGR-83.1-0AW	SGR-83.1-0A4W	84,2	85,2	104,1	7,5
SGR-84.2-2	SGR-84.2-2A4	SGR-84.2-3MFH	SGR-84.2-0AW	SGR-84.2-0A4W	85,3	86,2	104,1	7,5
SGR-85.2-2	SGR-85.2-2A4	SGR-85.2-3MFH	SGR-85.2-0AW	SGR-85.2-0A4W	86,3	87,2	116,8	7,5
SGR-86.3-2	SGR-86.3-2A4	SGR-86.3-3MFH	SGR-86.3-0AW	SGR-86.3-0A4W	87,3	88,4	116,8	7,5
SGR-87.4-2	SGR-87.4-2A4	SGR-87.4-3MFH	SGR-87.4-0AW	SGR-87.4-0A4W	88,5	89,4	116,8	7,5
SGR-88.4-2	SGR-88.4-2A4	SGR-88.4-3MFH	SGR-88.4-0AW	SGR-88.4-0A4W	89,5	90,4	116,8	7,5
SGR-89.4-2	SGR-89.4-2A4	SGR-89.4-3MFH	SGR-89.4-0AW	SGR-89.4-0A4W	90,5	91,6	116,8	7,5
SGR-90.6-2	SGR-90.6-2A4	SGR-90.6-3MFH	SGR-90.6-0AW	SGR-90.6-0A4W	91,7	92,6	116,8	7,5
SGR-91.6-2	SGR-91.6-2A4	SGR-91.6-3MFH	SGR-91.6-0AW	SGR-91.6-0A4W	92,7	93,6	116,8	7,5
SGR-92.6-2	SGR-92.6-2A4	SGR-92.6-3MFH	SGR-92.6-0AW	SGR-92.6-0A4W	93,7	94,7	116,8	7,5
SGR-93.8-2	SGR-93.8-2A4	SGR-93.8-3MFH	SGR-93.8-0AW	SGR-93.8-0A4W	94,8	95,8	116,8	7,5
SGR-94.8-2	SGR-94.8-2A4	SGR-94.8-3MFH	SGR-94.8-0AW	SGR-94.8-0A4W	95,9	96,8	116,8	7,5
SGR-95.8-2	SGR-95.8-2A4	SGR-95.8-3MFH	SGR-95.8-0AW	SGR-95.8-0A4W	96,9	97,9	116,8	7,5
SGR-96.9-2	SGR-96.9-2A4	SGR-96.9-3MFH	SGR-96.9-0AW	SGR-96.9-0A4W	98,0	98,9	116,8	7,5
SGR-97.9-2	SGR-97.9-2A4	SGR-97.9-3MFH	SGR-97.9-0AW	SGR-97.9-0A4W	99,0	99,9	129,5	7,5
SGR-99.0-2	SGR-99.0-2A4	SGR-99.0-3MFH	SGR-99.0-0AW	SGR-99.0-0A4W	100,0	101,1	129,5	7,5
SGR-100.1-2	SGR-100.1-2A4	SGR-100.1-3MFH	SGR-100.1-0AW	SGR-100.1-0A4W	101,2	102,1	129,5	7,5
SGR-101.1-2	SGR-101.1-2A4	SGR-101.1-3MFH	SGR-101.1-0AW	SGR-101.1-0A4W	102,2	103,1	129,5	7,5
SGR-102.1-2	SGR-102.1-2A4	SGR-102.1-3MFH	SGR-102.1-0AW	SGR-102.1-0A4W	103,2	104,3	129,5	7,5
SGR-103.3-2	SGR-103.3-2A4	SGR-103.3-3MFH	SGR-103.3-0AW	SGR-103.3-0A4W	104,4	105,3	129,5	7,5
SGR-104.3-2	SGR-104.3-2A4	SGR-104.3-3MFH	SGR-104.3-0AW	SGR-104.3-0A4W	105,4	106,3	129,5	7,5
SGR-105.3-2	SGR-105.3-2A4	SGR-105.3-3MFH	SGR-105.3-0AW	SGR-105.3-0A4W	106,4	107,4	129,5	7,5
SGR-106.5-2	SGR-106.5-2A4	SGR-106.5-3MFH	SGR-106.5-0AW	SGR-106.5-0A4W	107,5	108,5	129,5	7,5
SGR-107.5-2	SGR-107.5-2A4	SGR-107.5-3MFH	SGR-107.5-0AW	SGR-107.5-0A4W	108,6	109,5	129,5	7,5
SGR-108.5-2	SGR-108.5-2A4	SGR-108.5-3MFH	SGR-108.5-0AW	SGR-108.5-0A4W	109,6	110,6	129,5	7,5
SGR-109.6-2	SGR-109.6-2A4	SGR-109.6-3MFH	SGR-109.6-0AW	SGR-109.6-0A4W	110,7	111,6	129,5	7,5
SGR-110.6-2	SGR-110.6-2A4	SGR-110.6-3MFH	SGR-110.6-0AW	SGR-110.6-0A4W	111,7	112,6	142,2	7,5
SGR-111.7-2	SGR-111.7-2A4	SGR-111.7-3MFH	SGR-111.7-0AW	SGR-111.7-0A4W	112,7	113,8	142,2	7,5
SGR-112.8-2	SGR-112.8-2A4	SGR-112.8-3MFH	SGR-112.8-0AW	SGR-112.8-0A4W	113,9	114,8	142,2	7,5
SGR-113.8-2	SGR-113.8-2A4	SGR-113.8-3MFH	SGR-113.8-0AW	SGR-113.8-0A4W	114,9	115,8	142,2	7,5
SGR-114.8-2	SGR-114.8-2A4	SGR-114.8-3MFH	SGR-114.8-0AW	SGR-114.8-0A4W	115,9	117,0	142,2	7,5
SGR-116.0-2	SGR-116.0-2A4	SGR-116.0-3MFH	SGR-116.0-0AW	SGR-116.0-0A4W	117,1	118,0	142,2	7,5
SGR-117.0-2	SGR-117.0-2A4	SGR-117.0-3MFH	SGR-117.0-0AW	SGR-117.0-0A4W	118,1	119,0	142,2	7,5
SGR-118.0-2	SGR-118.0-2A4	SGR-118.0-3MFH	SGR-118.0-0AW	SGR-118.0-0A4W	119,1	120,1	142,2	7,5
SGR-119.2-2	SGR-119.2-2A4	SGR-119.2-3MFH	SGR-119.2-0AW	SGR-119.2-0A4W	120,2	121,2	142,2	7,5
SGR-120.2-2	SGR-120.2-2A4	SGR-120.2-3MFH	SGR-120.2-0AW	SGR-120.2-0A4W	121,3	122,2	142,2	7,5
SGR-121.2-2	SGR-121.2-2A4	SGR-121.2-3MFH	SGR-121.2-0AW	SGR-121.2-0A4W	122,3	123,3	142,2	7,5
SGR-122.3-2	SGR-122.3-2A4	SGR-122.3-3MFH	SGR-122.3-0AW	SGR-122.3-0A4W	123,4	124,3	142,2	7,5
SGR-123.3-2	SGR-123.3-2A4	SGR-123.3-3MFH	SGR-123.3-0AW	SGR-123.3-0A4W	124,4	125,3	154,9	7,5
SGR-124.4-2	SGR-124.4-2A4	SGR-124.4-3MFH	SGR-124.4-0AW	SGR-124.4-0A4W	125,4	126,5	154,9	7,5
SGR-125.5-2	SGR-125.5-2A4	SGR-125.5-3MFH	SGR-125.5-0AW	SGR-125.5-0A4W	126,6	127,5	154,9	7,5
SGR-126.5-2	SGR-126.5-2A4	SGR-126.5-3MFH	SGR-126.5-0AW	SGR-126.5-0A4W	127,6	128,5	154,9	7,5
SGR-127.5-2	SGR-127.5-2A4	SGR-127.5-3MFH	SGR-127.5-0AW	SGR-127.5-0A4W	128,6	129,7	154,9	7,5
SGR-128.7-2	SGR-128.7-2A4	SGR-128.7-3MFH	SGR-128.7-0AW	SGR-128.7-0A4W	129,8	130,7	154,9	7,5
SGR-129.7-2	SGR-129.7-2A4	SGR-129.7-3MFH	SGR-129.7-0AW	SGR-129.7-0A4W	130,8	131,7	154,9	7,5
SGR-130.7-2	SGR-130.7-2A4	SGR-130.7-3MFH	SGR-130.7-0AW	SGR-130.7-0A4W	131,8	132,8	154,9	7,5
SGR-131.9-2	SGR-131.9-2A4	SGR-131.9-3MFH	SGR-131.9-0AW	SGR-131.9-0A4W	132,9	133,9	154,9	7,5
SGR-132.9-2	SGR-132.9-2A4	SGR-132.9-3MFH	SGR-132.9-0AW	SGR-132.9-0A4W	134,0	134,9	154,9	7,5
SGR-133.9-2	SGR-133.9-2A4	SGR-133.9-3MFH	SGR-133.9-0AW	SGR-133.9-0A4W	135,0	136,0	154,9	7,5
SGR-135.0-2	SGR-135.0-2A4	SGR-135.0-3MFH	SGR-135.0-0AW	SGR-135.0-0A4W	136,1	137,0	154,9	7,5
SGR-136.0-2	SGR-136.0-2A4	SGR-136.0-3MFH	SGR-136.0-0AW	SGR-136.0-0A4W	137,1	138,0	167,6	7,5
SGR-137.1-2	SGR-137.1-2A4	SGR-137.1-3MFH	SGR-137.1-0AW	SGR-137.1-0A4W	138,1	139,2	167,6	7,5
SGR-138.2-2	SGR-138.2-2A4	SGR-138.2-3MFH	SGR-138.2-0AW	SGR-138.2-0A4W	139,3	140,2	167,6	7,5
SGR-139.2-2	SGR-139.2-2A4	SGR-139.2-3MFH	SGR-139.2-0AW	SGR-139.2-0A4W	140,3	141,2	167,6	7,5
SGR-140.2-2	SGR-140.2-2A4	SGR-140.2-3MFH	SGR-140.2-0AW	SGR-140.2-0A4W	141,3	142,4	167,6	7,5
SGR-141.4-2	SGR-141.4-2A4	SGR-141.4-3MFH	SGR-141.4-0AW	SGR-141.4-0A4W	142,5	143,4	167,6	7,5
SGR-142.4-2	SGR-142.4-2A4	SGR-142.4-3MFH	SGR-142.4-0AW	SGR-142.4-0A4W	143,5	144,4	167,6	7,5
SGR-143.4-2	SGR-143.4-2A4	SGR-143.4-3MFH	SGR-143.4-0AW	SGR-143.4-0A4W	144,5	145,5	167,6	7,5
SGR-144.6-2	SGR-144.6-2A4	SGR-144.6-3MFH	SGR-144.6-0AW	SGR-144.6-0A4W	145,6	146,6	167,6	7,5
SGR-145.6-2	SGR-145.6-2A4	SGR-145.6-3MFH	SGR-145.6-0AW	SGR-145.6-0A4W	146,7	147,6	167,6	7,5
SGR-146.6-2	SGR-146.6-2A4	SGR-146.6-3MFH	SGR-146.6-0AW	SGR-146.6-0A4W	147,7	148,7	167,6	7,5
SGR-147.7-2	SGR-147.7-2A4	SGR-147.7-3MFH	SGR-147.7-0AW	SGR-147.7-0A4W	148,8	149,7	167,6	7,5
SGR-148.7-2	SGR-148.7-2A4	SGR-148.7-3MFH	SGR-148.7-0AW	SGR-148.7-0A4W	149,8	150,7	180,3	7,5
SGR-149.8-2	SGR-149.8-2A4	SGR-149.8-3MFH	SGR-149.8-0AW	SGR-149.8-0A4W	150,8	151,9	180,3	7,5
SGR-150.9-2	SGR-150.9-2A4	SGR-150.9-3MFH	SGR-150.9-0AW	SGR-150.9-0A4W	152,0	152,9	180,3	7,5

*Custom Part-No Return

*Custom Part-No Return



BEARING CURRENTS

MOTOR GROUNDING

AEGIS® TECHNOLOGY

LOW VOLTAGE MOTORS

MED VOLTAGE MOTORS

DC MOTORS

INSTALL SHAFT PREP

SHAFT VOLTAGE TESTING

SELECT CORRECT SIZE

PARTS LIST

ENGINEERING SPEC

AEGIS® SGR - Press Fit Mounting for Low Voltage Motors to 375 kW

Note: Use PRO Series Rings for Low Voltage Motors Greater than 375 kW and All Medium Voltage Motors
See page 22

BEARING CURRENTS

MOTOR GROUNDING

AEGIS® TECHNOLOGY

LOW VOLTAGE MOTORS

MED VOLTAGE MOTORS

DC MOTORS

INSTALL SHAFT PREP

SHAFT VOLTAGE TESTING

SELECT CORRECT SIZE

PARTS LIST

ENGINEERING SPEC

Catalog Number	Min. shaft diameter	Max. shaft diameter	SGR OD Tolerance +0/-0,025	Thickness Max	Bore Tolerance +0,025/-0
SGR-6.9-0A6	7,9	9,0	40,132	7,5	40,030
SGR-8.0-0A6	9,1	10,0	40,132	7,5	40,030
SGR-9.0-0A6	10,1	11,0	40,132	7,5	40,030
SGR-10.1-0A6	11,1	12,2	40,132	7,5	40,030
SGR-11.2-0A6	12,3	13,2	40,132	7,5	40,030
SGR-12.2-0A6	13,3	14,2	40,132	7,5	40,030
SGR-13.2-0A6	14,3	15,4	40,132	7,5	40,030
SGR-14.4-0A6	15,5	16,4	40,132	7,5	40,030
SGR-15.4-0A6	16,5	17,4	52,832	7,5	52,730
SGR-16.4-0A6	17,5	18,5	52,832	7,5	52,730
SGR-17.6-0A6	18,6	19,7	52,832	7,5	52,730
SGR-18.7-0A6	19,8	20,7	52,832	7,5	52,730
SGR-19.7-0A6	20,8	21,7	52,832	7,5	52,730
SGR-20.7-0A6	21,8	22,7	52,832	7,5	52,730
SGR-21.7-0A6	22,8	23,7	52,832	7,5	52,730
SGR-22.8-0A6	23,8	24,9	52,832	7,5	52,730
SGR-23.9-0A6	25,0	25,9	52,832	7,5	52,730
SGR-24.9-0A6	26,0	26,9	52,832	7,5	52,730
SGR-25.9-0A6	27,0	28,1	52,832	7,5	52,730
SGR-27.1-0A6	28,2	29,1	52,832	7,5	52,730
SGR-28.1-0A6	29,2	30,1	52,832	7,5	52,730
SGR-29.1-0A6	30,2	31,2	52,832	7,5	52,730
SGR-30.3-0A6	31,3	32,3	52,832	7,5	52,730
SGR-31.3-0A6	32,4	33,3	52,832	7,5	52,730
SGR-32.3-0A6	33,4	34,4	52,832	7,5	52,730
SGR-33.4-0A6	34,5	35,4	52,832	7,5	52,730
SGR-34.4-0A6	35,5	36,4	67,564	7,5	67,462
SGR-35.5-0A6	36,5	37,6	67,564	7,5	67,462
SGR-36.6-0A6	37,7	38,6	67,564	7,5	67,462
SGR-37.6-0A6	38,7	39,6	67,564	7,5	67,462
SGR-38.6-0A6	39,7	40,8	67,564	7,5	67,462
SGR-39.8-0A6	40,9	41,8	67,564	7,5	67,462
SGR-40.8-0A6	41,9	42,8	67,564	7,5	67,462
SGR-41.8-0A6	42,9	43,9	67,564	7,5	67,462
SGR-43.0-0A6	44,0	45,0	67,564	7,5	67,462
SGR-44.0-0A6	45,1	46,0	67,564	7,5	67,462
SGR-45.0-0A6	46,1	47,1	67,564	7,5	67,462
SGR-46.1-0A6	47,2	48,1	67,564	7,5	67,462
SGR-47.1-0A6	48,2	49,1	67,564	7,5	67,462
SGR-48.2-0A6	49,2	50,3	67,564	7,5	67,462
SGR-49.3-0A6	50,4	51,3	67,564	7,5	67,462
SGR-50.3-0A6	51,4	52,3	78,232	7,5	78,130
SGR-51.3-0A6	52,4	53,5	78,232	7,5	78,130
SGR-52.5-0A6	53,6	54,5	78,232	7,5	78,130
SGR-53.5-0A6	54,6	55,5	78,232	7,5	78,130
SGR-54.5-0A6	55,6	57,5	78,232	7,5	78,130
SGR-55.7-0A6	56,7	57,7	78,232	7,5	78,130
SGR-56.7-0A6	57,8	58,7	78,232	7,5	78,130
SGR-57.7-0A6	58,8	59,8	78,232	7,5	78,130
SGR-58.8-0A6	59,9	60,8	78,232	7,5	78,130
SGR-59.8-0A6	60,9	61,8	90,932	7,5	90,830
SGR-60.9-0A6	61,9	63,0	90,932	7,5	90,830
SGR-62.0-0A6	63,1	64,0	90,932	7,5	90,830
SGR-63.0-0A6	64,1	65,0	90,932	7,5	90,830
SGR-64.0-0A6	65,1	66,2	90,932	7,5	90,830
SGR-65.2-0A6	66,3	67,2	90,932	7,5	90,830
SGR-66.2-0A6	67,3	68,2	90,932	7,5	90,830
SGR-67.2-0A6	68,3	69,3	90,932	7,5	90,830
SGR-68.4-0A6	69,4	70,4	90,932	7,5	90,830
SGR-69.4-0A6	70,5	71,4	90,932	7,5	90,830
SGR-70.4-0A6	71,5	72,5	90,932	7,5	90,830
SGR-71.5-0A6	72,6	73,5	90,932	7,5	90,830
SGR-72.5-0A6	73,6	74,5	103,632	7,5	103,530
SGR-73.6-0A6	74,6	75,7	103,632	7,5	103,530
SGR-74.7-0A6	75,8	76,7	103,632	7,5	103,530
SGR-75.7-0A6	76,8	77,7	103,632	7,5	103,530
SGR-76.7-0A6	77,8	78,9	103,632	7,5	103,530
SGR-77.9-0A6	79,0	79,9	103,632	7,5	103,530
SGR-78.9-0A6	80,0	80,9	103,632	7,5	103,530

Custom Part-No Return

Catalog Number	Min. shaft diameter	Max. shaft diameter	SGR OD Tolerance +0/-0,025	Thickness Max	Bore Tolerance +0,025/-0
SGR-79.9-0A6	81,0	82,0	103,632	7,5	103,530
SGR-81.1-0A6	82,1	83,1	103,632	7,5	103,530
SGR-82.1-0A6	83,2	84,1	103,632	7,5	103,530
SGR-83.1-0A6	84,2	85,2	103,632	7,5	103,530
SGR-84.2-0A6	85,3	86,2	103,632	7,5	103,530
SGR-85.2-0A6	86,3	87,2	116,332	7,5	116,230
SGR-86.3-0A6	87,3	88,4	116,332	7,5	116,230
SGR-87.4-0A6	88,5	89,4	116,332	7,5	116,230
SGR-88.4-0A6	89,5	90,4	116,332	7,5	116,230
SGR-89.4-0A6	90,5	91,6	116,332	7,5	116,230
SGR-90.6-0A6	91,7	92,6	116,332	7,5	116,230
SGR-91.6-0A6	92,7	93,6	116,332	7,5	116,230
SGR-92.6-0A6	93,7	94,7	116,332	7,5	116,230
SGR-93.8-0A6	94,8	95,8	116,332	7,5	116,230
SGR-94.8-0A6	95,9	96,8	116,332	7,5	116,230
SGR-95.8-0A6	96,9	97,9	116,332	7,5	116,230
SGR-96.9-0A6	98,0	98,9	116,332	7,5	116,230
SGR-97.9-0A6	99,0	99,9	129,032	7,5	128,930
SGR-99.0-0A6	100,0	101,1	129,032	7,5	128,930
SGR-100.1-0A6	101,2	102,1	129,032	7,5	128,930
SGR-101.1-0A6	102,2	103,1	129,032	7,5	128,930
SGR-102.1-0A6	103,2	104,3	129,032	7,5	128,930
SGR-103.3-0A6	104,4	105,3	129,032	7,5	128,930
SGR-104.3-0A6	105,4	106,3	129,032	7,5	128,930
SGR-105.3-0A6	106,4	107,4	129,032	7,5	128,930
SGR-106.5-0A6	107,5	108,5	129,032	7,5	128,930
SGR-107.5-0A6	108,6	109,5	129,032	7,5	128,930
SGR-108.5-0A6	109,6	110,6	129,032	7,5	128,930
SGR-109.6-0A6	110,7	111,6	129,032	7,5	128,930
SGR-110.6-0A6	111,7	112,6	141,732	7,5	141,630
SGR-111.7-0A6	112,7	113,8	141,732	7,5	141,630
SGR-112.8-0A6	113,9	114,8	141,732	7,5	141,630
SGR-113.8-0A6	114,9	115,8	141,732	7,5	141,630
SGR-114.8-0A6	115,9	117,0	141,732	7,5	141,630
SGR-116.0-0A6	117,1	118,0	141,732	7,5	141,630
SGR-117.0-0A6	118,1	119,0	141,732	7,5	141,630
SGR-118.0-0A6	119,1	120,1	141,732	7,5	141,630
SGR-119.2-0A6	120,2	121,2	141,732	7,5	141,630
SGR-120.2-0A6	121,3	122,2	141,732	7,5	141,630
SGR-121.2-0A6	122,3	123,3	141,732	7,5	141,630
SGR-122.3-0A6	123,4	124,3	141,732	7,5	141,630
SGR-123.3-0A6	124,4	125,3	154,432	7,5	154,330
SGR-124.4-0A6	125,4	126,5	154,432	7,5	154,330
SGR-125.5-0A6	126,6	127,5	154,432	7,5	154,330
SGR-126.5-0A6	127,6	128,5	154,432	7,5	154,330
SGR-127.5-0A6	128,6	129,7	154,432	7,5	154,330
SGR-128.7-0A6	129,8	130,7	154,432	7,5	154,330
SGR-129.7-0A6	130,8	131,7	154,432	7,5	154,330
SGR-130.7-0A6	131,8	132,8	154,432	7,5	154,330
SGR-131.9-0A6	132,9	133,9	154,432	7,5	154,330
SGR-132.9-0A6	134,0	134,9	154,432	7,5	154,330
SGR-133.9-0A6	135,0	136,0	154,432	7,5	154,330
SGR-135.0-0A6	136,1	137,0	154,432	7,5	154,330
SGR-136.0-0A6	137,1	138,0	167,132	7,5	167,030
SGR-137.1-0A6	138,1	139,2	167,132	7,5	167,030
SGR-138.2-0A6	139,3	140,2	167,132	7,5	167,030
SGR-139.2-0A6	140,3	141,2	167,132	7,5	167,030
SGR-140.2-0A6	141,3	142,4	167,132	7,5	167,030
SGR-141.4-0A6	142,5	143,4	167,132	7,5	167,030
SGR-142.4-0A6	143,5	144,4	167,132	7,5	167,030
SGR-143.4-0A6	144,5	145,5	167,132	7,5	167,030
SGR-144.6-0A6	145,6	146,6	167,132	7,5	167,030
SGR-145.6-0A6	146,7	147,6	167,132	7,5	167,030
SGR-146.6-0A6	147,7	148,7	167,132	7,5	167,030
SGR-147.7-0A6	148,8	149,7	167,132	7,5	167,030
SGR-148.7-0A6	149,8	150,7	179,832	7,5	179,730
SGR-149.8-0A6	150,8	151,9	179,832	7,5	179,730
SGR-150.9-0A6	152,0	152,9	179,832	7,5	179,730

Custom Part-No Return

Dimensions in mm



Patented Technology

AEGIS® uKIT with Universal Mounting IEC Motors for Low Voltage Motors to 375 kW



- Kit is designed to avoid any slinger or shaft shoulder. Order based on IEC or NEMA Frame size.
- Install with 3 or 4 brackets depending on motor end bracket design.
- uKIT can be attached to motor with screws/washers provided or with conductive epoxy. AEGIS® EP2400 Conductive Epoxy sold separately.
- See AEGIS® website for bolt hole circle and installation. www.est-aegis.com/uKIT



AEGIS® EP2400 Conductive Epoxy installation



Solid Ring with 3 brackets

IEC uKIT - Solid Ring Catalog Number	IEC uKIT - Split Ring Catalog Number	Motor shaft dia "d"	IEC Frame
SGR-19-UKIT	SGR-19-UKIT-2A4	19mm	
SGR-24-UKIT	SGR-24-UKIT-2A4	24mm	
SGR-28-UKIT	SGR-28-UKIT-2A4	28mm	IEC 100L, 112M (2, 4, 6, 8 pole)
SGR-38-UKIT	SGR-38-UKIT-2A4	38mm	IEC 132S, 132M (2, 4, 6, 8 pole)
SGR-42-UKIT	SGR-42-UKIT-2A4	42mm	IEC 160M, 160L (2, 4, 6, 8 pole)
SGR-48-UKIT	SGR-48-UKIT-2A4	48mm	IEC 180M, 180L (2, 4, 6, 8 pole)
SGR-55-UKIT	SGR-55-UKIT-2A4	55mm	IEC 200L (2, 4, 6, 8 pole), IEC 225S, 225M (2 pole)
SGR-60-UKIT	SGR-60-UKIT-2A4	60mm	IEC 225S, 225M (4, 6, 8 pole), IEC 250M (2 pole)
SGR-65-UKIT	SGR-65-UKIT-2A4	65mm	IEC 250M (4, 6, 8 pole), IEC 280M, 280S, 315S, 315M, 315L (2 pole)
SGR-70-UKIT	SGR-70-UKIT-2A4	70mm	
SGR-75-UKIT	SGR-75-UKIT-2A4	75mm	IEC 280S, 280M (4, 6, 8 pole), IEC 355M, 355L (2 pole)
SGR-80-UKIT	SGR-80-UKIT-2A4	80mm	IEC 315S, 315M, 315L (4, 6, 8 pole)
SGR-85-UKIT	SGR-85-UKIT-2A4	85mm	
SGR-90-UKIT	SGR-90-UKIT-2A4	90mm	
SGR-95-UKIT	SGR-95-UKIT-2A4	95mm	IEC 335L, 335M, 355L, 355M (4, 6, 8, 10 pole)
SGR-100-UKIT	SGR-100-UKIT-2A4	100mm	
SGR-110-UKIT	SGR-110-UKIT-2A4	110mm	

Includes: AEGIS® SGR Shaft Grounding Ring, (4) universal brackets of each size - 16 total, (4) 5-40 x 3/8" flat head screws, (4) M4 x 10 socket head cap screws, (4) M4 split lock washers, (4) M4 flat washers, 5/64" allen wrench, 3mm allen wrench

BEARING CURRENTS

MOTOR GROUNDING

AEGIS® TECHNOLOGY

LOW VOLTAGE MOTORS

MED VOLTAGE MOTORS

DC MOTORS

INSTALL SHAFT PREP

SHAFT VOLTAGE TESTING

SELECT CORRECT SIZE

PARTS LIST

ENGINEERING SPEC



BEARING CURRENTS

MOTOR GROUNDING

AEGIS® TECHNOLOGY

LOW VOLTAGE MOTORS

MED VOLTAGE MOTORS

DC MOTORS

INSTALL SHAFT PREP

SHAFT VOLTAGE TESTING

SELECT CORRECT SIZE

PARTS LIST

ENGINEERING SPEC

AEGIS® PRO Series

for Low Voltage Motors Greater than 375 kW, All Medium Voltage Motors and DC Motors over 225 kW



Bolt Through Mounting (4x)

AEGIS® PRO Series

AEGIS® PROSL
AEGIS® PROSLR
AEGIS® PROMR
AEGIS® PROMAX

Shaft Diameter 63,5mm to 762mm
High Current Bearing Protection for Large Motors over 375 kW and Generators (Medium Voltage-greater than 600 volts AC)

Part numbers based on shaft diameter
To size ring, see page 27
Drawings available upon request

Solid and Split Ring design (PROMAX split only)
6 rows of fiber

Includes bolt through mounting hardware
Ships with CS015 Colloidal Silver Shaft Coating
Custom brackets available upon request

AEGIS® WTG



Bolt Through Mounting (4x)

AEGIS® WTGSL Wind Turbine Grounding

Shaft Diameter 63,5mm to 400mm
High Current Bearing Protection for Wind Turbine Generators

Outside Diameter: Shaft Diameter + 47,24mm
Part numbers based on shaft diameter
Drawings available upon request

Solid and Split Ring design
6 rows of fiber

Includes bolt through mounting hardware
Ships with CS015 Colloidal Silver Shaft Coating
Custom brackets available upon request



See AEGIS website for more details:
www.est-aegis.com/WTG



Patented Technology

Optional Mounting Brackets for AEGIS® PRO Series and WTGSL

For AEGIS® PROSL, PROSLR, PROMR, WTGSL



AEGIS® PRO Brackets

These brackets can be used with the AEGIS® PRO Series and AEGIS® WTGSL

Part Number: **BKT-PRO-2**

- (4) Universal brackets
- (4) 19mm x 12,7mm spacers
- (4) 19mm x 25,4mm spacers
- (4) 19mm x 38,1mm spacers
- (4) M8 x 35mm SHCS
- (4) M8 x 45mm SHCS
- (4) M8 x 60mm SHCS
- (4) flat washers
- (4) lock washers

Custom Brackets/Installation Examples

Contact our Engineering Team for special mounting applications.



Custom Split Mounting Plate with tie bars



Bearing Cap Mounting



Custom Mounting Brackets



BEARING
CURRENTS

MOTOR
GROUNDING

AEGIS®
TECHNOLOGY

LOW VOLTAGE
MOTORS

MED VOLTAGE
MOTORS

DC
MOTORS

INSTALL
SHAFT PREP

SHAFT VOLTAGE
TESTING

SELECT
CORRECT SIZE

PARTS
LIST

ENGINEERING
SPEC

AEGIS® Shaft Voltage Tester™



The AEGIS® Shaft Voltage Tester™ kit includes everything you need to start testing motor shaft voltages. At its core is a 2 channel, 100 MHz digital oscilloscope with a 5.7" screen and easy screen capture.

	AEGIS-OSC-9100-W2-I	AEGIS-OSC-9100 MB-W2-I	AEGIS-OSC-9100 MB-W2-IC
AEGIS® Shaft Voltage Tester™ Digital Oscilloscope	■	■	■
AEGIS® Shaft Voltage Probe™ with Tip Installed	■	■	■
Spare 1X/10X Oscilloscope Probe	■	■	■
USB Probe Calibration Dongle	■	■	■
Multimeter Test Leads	■	■	■
Rechargeable/replaceable Battery	■	■	■
Power Supply (9V, 4A DC; 120/240 VAC)	■	■	■
Compact Carrying Case	■	■	■
USB Flash drive, loaded with manual	■	■	■
AEGIS® Bearing Protection Handbook	■	■	■
Universal Power Adapter	■	■	■
Alligator Grounding Clips	1	2	2
Spare AEGIS® Shaft Voltage Probe™ Tips		3	3
AEGIS® Shaft Grounding Simulator™		■	■
Probe Holder		■	■
Magnetic Base		■	■
ISO 17025 Calibration			■
Warranty Length	2 years	2 years	2 years



Catalog Number	Includes:
SVP-KIT-9100MB	3 SVP tips, probe holder with two piece extension rod (total length of probe holder with extension rod is 45cm), AEGIS® Grounding Simulator with alligator ground clip, and magnetic base.
AEGIS-SVP-510	AEGIS® Shaft Voltage Probe™ PP510 with BNC connector. 1 AEGIS® SVP Tip 1 alligator ground clip
SVP-TIP-9100	3 SVP replacement tips only
BAT-9100	Spare/replacement battery



Patented Technology

AEGIS® HFGS and Accessories

BEARING CURRENTS

MOTOR GROUNDING

AEGIS® TECHNOLOGY

LOW VOLTAGE MOTORS

MED VOLTAGE MOTORS

DC MOTORS

INSTALL SHAFT PREP

SHAFT VOLTAGE TESTING

SELECT CORRECT SIZE

PARTS LIST

ENGINEERING SPEC

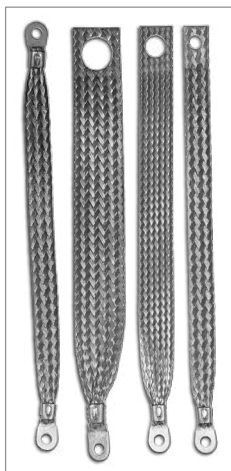

AEGIS® HFGS High-Frequency Ground Strap Length: 305mm and 610mm		
Catalog Number	Terminations	Fits Frame Sizes:
HFGS-T0410-R0312-12 305mm HFGS-T0410-R0312-24 610mm	Term 1: Punched hole 10mm Term 2: Ring terminal for 8mm screws	IEC: 80M, 90S, 90L NEMA: 48, 48H, 56, 56H, 143T, 145T, 182T, 184T, 213T, 215T
HFGS-T0660-R0312-12 305mm HFGS-T0660-R0312-24 610mm	Term 1: Punched hole 17mm Term 2: Ring terminal for 8mm screws	IEC: 100S, 100L, 112S, 112M, 132S, 132M, 160S, 160M, 160L, 180S, 180M, 180L NEMA: 254T, 256T, 284T, 284TS, 286T, 286TS, 324T, 324TS, 326T, 326TS, 364T, 364TS, 365T, 365TS
HFGS-T0940-R0312-12 305mm HFGS-T0940-R0312-24 610mm	Term 1: Punched hole 24mm Term 2: Ring terminal for 8mm screws	IEC: 200S, 200M, 200L, 225S, 225M, 250S, 250M, 280S, 280M NEMA: 404T, 404TS, 405T, 405TS, 444T, 444TS, 445T, 445TS, 447T, 447TS, 449T, 449TS
HFGS-R0312-R0312-12 305mm HFGS-R0312-R0312-24 610mm	Term 1: Ring terminal for 8mm screws Term 2: Ring terminal for 8mm screws	NEMA/IEC: universal terminations
Screws included Custom lengths and terminations available on request		



AEGIS® Colloidal Silver Shaft Coating	
Catalog Number	Coverage:
CS015	20-25 applications based on a 76mm shaft diameter
Used to improve the conductivity of the steel shaft surface. Apply to any VFD driven motor shaft prior to installing the AEGIS® Shaft Grounding Ring.	
Note: Shelf life is 6 months. Non-returnable.	
GHS SDS available at www.est-aegis.com	



AEGIS® Conductive Epoxy	
Catalog Number	Coverage:
EP2400	2-3 applications
Used to install the AEGIS® Shaft Grounding Ring without drilling and tapping into the motor end bell.	
Note: Shelf life is 9 months. Non-returnable.	
GHS SDS available at www.est-aegis.com	



Motors Controlled by PWM Drives (VFD) Electrical Bearing Damage Protection

Engineering Specification:

Construction Specification Institute Section 23 05 13

MOTORS

23 05

2.1 MOTORS

A. General Requirements – Shaft Grounding:

1. All motors operated on variable frequency drives shall be equipped with a maintenance free, conductive micro fiber, shaft grounding ring with a minimum of two rows of circumferential micro fibers to discharge damaging shaft voltages away from the bearings to ground.
2. Application Note: Motors up to 100HP (75 kW) shall be provided with one shaft grounding ring installed either on the drive end or non-drive end. Motors over 100HP (75kW) shall be provided with an insulated bearing on the non-drive end and a shaft grounding ring on the drive end of the motor. Grounding rings shall be provided and installed by the motor manufacturer or contractor and shall be installed in accordance with the manufacturer’s recommendations.

B. General Requirements – High-Frequency Bonding:

1. All motors operated on variable frequency drives shall be bonded from the motor foot to system ground with a high frequency ground strap made of flat braided, tinned copper with terminations to accommodate motor foot and system ground connection.
2. Application Note: Proper grounding of motor frame for all inverter-driven induction motors

References:

- a. ABB Technical Guide No.5
- b. Allen Bradley Publication 1770-4.1 Application Data, Industrial Automation Wiring and Grounding Guidelines

Recommended parts: AEGIS® Shaft Grounding Ring
AEGIS® High Frequency Ground Strap

Recommended source: Electro Static Technology-ITW
Manufacturer of AEGIS® Shaft Grounding Ring
Ph: 207.998.5140 | sales@est-aegis.com | www.est-aegis.com

Detail sheets for the AEGIS® Ring and the High Frequency Ground Strap can be downloaded at www.est-aegis.com/specs.php

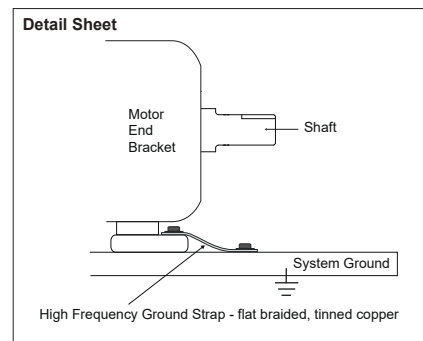
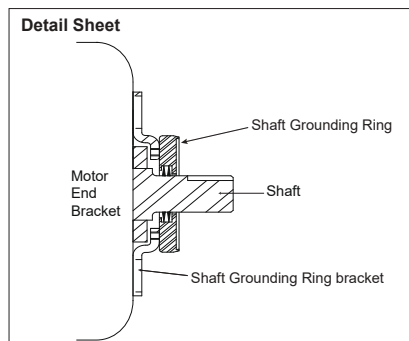

WARRANTY: Units are guaranteed for one year from date of purchase against defective materials and workmanship. Replacement will be made except for defects caused by abnormal use or mishandling. All statements and technical information contained herein, or presented by the manufacturer or his representative are rendered in good faith. User must assume responsibility to determine suitability of the product for intended use. The manufacturer shall not be liable for any injury, loss or damage, direct or consequential arising out of the use, or attempt to use the product.

The following patents apply: 8199453, 8169766, 7193836, 7136271, 7528513, 7339777, and other patents pending.



Patented Technology



Register your motor for the AEGIS® 2-Year Warranty Against Bearing Fluting Damage



Electro Static Technology (EST, AEGIS®) guarantees that AC induction motor bearings will not fail from electrical fluting damage when AEGIS® Shaft Grounding Rings have been installed with new bearings in accordance with EST's recommended best practices, as published in the AEGIS® Bearing Protection Handbook (current edition).

- The AC induction motor must meet the conditions listed below and new bearings must be installed at the time of AEGIS® Ring installation for the warranty to be approved.
- For repaired motors or for field installations: Upon registration and approval the warranty shall be for 2 years from the installation date of the new motor bearings and AEGIS Ring.
- For new motors with AEGIS® rings installed by the motor manufacturer: Upon registration the warranty shall be for a 2 year period after the motor manufacturer's bearing warranty ends.
- If electrically induced bearing fluting damage occurs, EST will pay the current Vaughen's National Average Price for "Furnish/Install 2 Standard Ball Bearings" and will supply a new shaft grounding ring (SGR or PRO as appropriate) and CS015. The warranty shall apply to any AC induction motor whether new or repaired which conforms to the AEGIS® Bearing Protection Handbook's best practices.

Conditions:

1. For All Motors: New bearings MUST be installed at the time of AEGIS® Ring installation.
2. All Motors: For this warranty to be valid, the owner must register the motor within 30 days of receipt, by filling out and submitting the information at www.est-aegis.com/warranty.
3. For AC Induction motors up to 75 kW: The warranty shall apply when AEGIS® Rings have been installed on the motor per the AEGIS® Bearing Protection Handbook's best practices.
4. AC Induction motors greater than 75 kW: The warranty shall apply when AEGIS® Rings and insulated bearings/insulation have been installed on the motor per the AEGIS® Bearing Protection Handbook's best practices.
5. AC Induction motors greater than 375 kW and ANY motor with supply voltage of greater than 600 VAC (medium/high voltage): The warranty shall only apply when AEGIS® PRO Series Rings and insulated bearings/insulation have been installed on the motor per the AEGIS® Bearing Protection Handbook's best practices.
6. The best practices shall apply per the current edition of the AEGIS® Bearing Protection Handbook at the time of installation.
7. Selection of the applicable ring (AEGIS® SGR or PRO Series) must conform to the requirements in the AEGIS® Bearing Protection Handbook.
8. The owner of the motor must verify that the installation of AEGIS® Rings and bearing insulation, if applicable, was per the AEGIS® Bearing Protection Handbook's best practices in order to receive approval for the warranty.
9. EST shall retain the sole authority to issue and approve the warranty for any application.
10. The warranty shall be activated and conferred to the motor owner upon the issuance by EST of an email or certificate confirming warranty acceptance.





Award Winning Technology



CONSULTING - SPECIFYING
engineer.

2009
PRODUCT OF THE YEAR

Finalist



CONSULTING - SPECIFYING
engineer.

2011
PRODUCT OF THE YEAR

Gold



Electro Static Technology™
An ITW Company

31 Winterbrook Road
Mechanic Falls ME 04256 USA
Toll Free: 1-866-738-1857
Ph: 207-998-5140
Email: sales@est-aegis.com
www.est-aegis.com

Contacts in Europe:

Martin Deiss
Sales Manager Europe
Mobile: +49 172 6273516
martin.deiss@est-aegis.com

William Klock
Sales Manager France and Benelux
Mobile: +33 770 253594
william.klock@est-aegis.com

Jens Leipner
Sales Manager North Europe
Mobile: +49 151 44654488
jens.leipner@est-aegis.com