

Horsepower: 1 – 30 HP

Speeds: 3600, 1800 and 1200 RPM

Design Voltages: 230/460, 460 & 575 Volts

Insulation: Class F insulation with Class B
Temperature Rise at Full Load

Enclosure: Totally Enclosed Fan Cooled (TEFC)

Efficiency Level: NEMA Premium^{®†} Efficient

Warranty: 3-years Limited Warranty



Product Overview and Options

U.S. Motors[®] brand e|line[®] motors are considered one of the toughest built to withstand a variety of severe duty applications. The e|line motor has an all cast iron frame, conduit box, fan cover, bearing caps, and end shields. These features, along with chemical resistant paint, help protect the motor from external damage in corrosive and harsh environments. Internal protection helps extend the thermal and mechanical life of the motor including a Class H Varnish Vacuum Pressure Impregnation (VPI).

Product Features:

- NEMA Premium^{®†} Efficient
- 1.20 and up to 1.40 Service Factor
- Class B Temperature Rise at 1.0 Service Factor by resistance with sine wave power.
- Class F Insulation System with Class H Varnish.
- NEMA Design B with Design C capability
Stainless Steel Nameplate with 50 & 60 Hz ratings.
- "V" ring with umbrella Seal Cover for IP55 Protection
- VFD or Full voltage across-the-line starting
- Suitable for Class I, Division 2, T2B
- Same Size Double Shielded Bearings on both End
- Locked Bearing on Pulley End (C-Flange Models Only)

Suitable for Variable Frequency Operation:

e|line patented inverter grade insulation system allows motor to withstand spike and transient voltages induced by insulated bipolar gate transistor drives, making the insulation fully compliant with NEMA MG-1, Part 31 with a speed ratio of 10:1 CT or 20:1 VT. This is made possible through:

- Pulse-resistant magnetic wire that provides protection against high-voltage spikes. (Class H Varnish)
- Additional lacing on the end turns improve coil rigidity
- Multiple bake cycles to help prevent coil-to-coil circuits
- Phase paper to help prevent phase-to-phase arcs

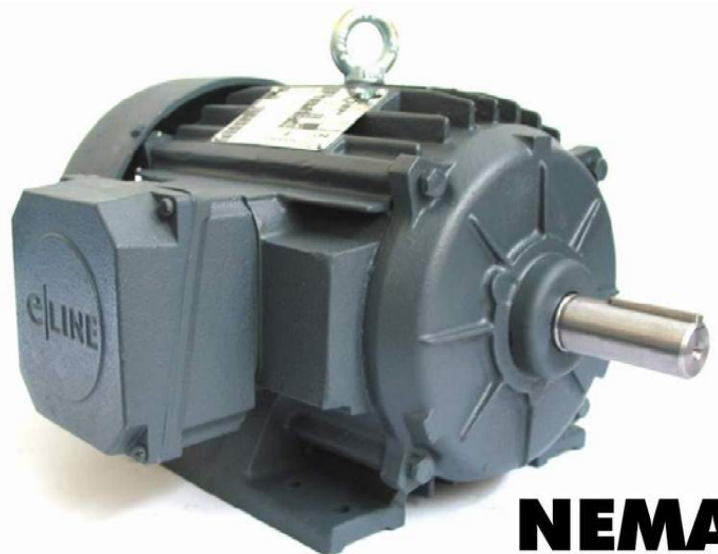

Product Overview and Options *Continued*

Typical e|line Motor Construction:

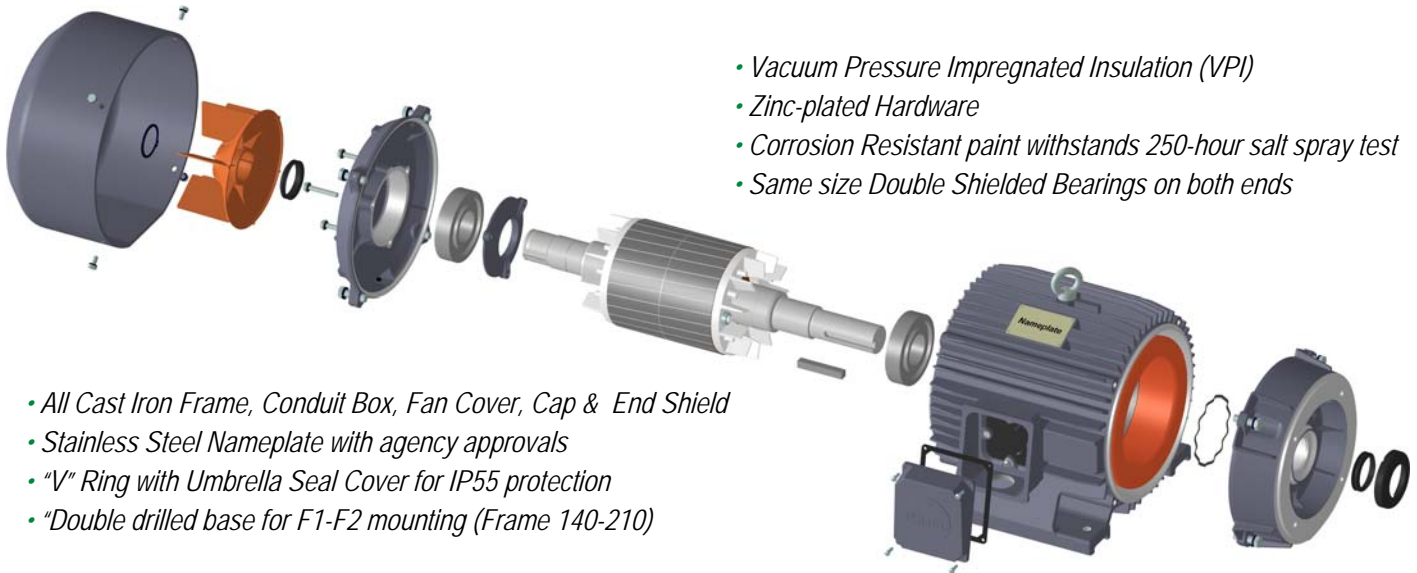

- Vacuum Pressure Impregnated Insulation (VPI)
- Zinc-plated Hardware
- Corrosion Resistant paint withstands 250-hour salt spray test
- Same size Double Shielded Bearings on both ends

- All Cast Iron Frame, Conduit Box, Fan Cover, Cap & End Shield
- Stainless Steel Nameplate with agency approvals
- "V" Ring with Umbrella Seal Cover for IP55 protection
- "Double drilled base for F1-F2 mounting (Frame 140-210)

Options and Accessories

Custom design options are available for U.S. Motors® brand e|line® motors:

- Field Convertible C-Flange Kits available
- Drip Cover, Canopy Cap Kits
- High Altitude or High Ambient de-rating capabilities
- 50 Hertz Voltage de-rating capabilities
- Winding thermal protection, Thermistors
- Space Heaters 115 Volts
- Terminal Block in Main Conduit Box



Testing and Submittals

Nidec Motor Canada Corporation conducts extensive type test on the U.S. Motors® brand e|line® motors:

- Insulation Resistance test by megohmmeter and polarization index
- High Potential test on Stator Windings
- Load and No Load Test (Current, Power and Speed)
- Dynamometer Correction Test
- Optional Speed Torque and Performance Curves available

For additional information, please contact your Nidec Motor Canada Corporation representative.

Western Canada & Ontario: 1-800-268-7913

Québec & Maritimes: 1-800-361-5509

† All marks shown within this document are properties of their respective owners.
Nidec Motor Canada Corporation, 2013: All Rights Reserved. U.S. Motors® is a registered trademark of Nidec Motor Corporation.