



BEAVER ELECTRICAL MACHINERY
 7440 LOWLAND DRIVE, BURNABY, BC, CANADA
 TEL: (604) 431-5000 FAX: (604) 431-5066
 www.beaverelectrical.com

**TER SERIES
 SPECIFICATION SHEET**

**3 PHASE TRANSFORMER
 TYPE: EPOXY ENCAPSULATED
 FLOOR OR WALL MOUNT**

CAT. NO.: TER6T-Q34C
 KVA: 6
 PRIMARY VOLT: 600▲
 SECONDARY VOLT: 400Y/230
 PHASE: 3
 FREQ: 60 HZ
 WINDING MATL: Copper
 WEIGHT: 200 LBS
 INSUL. CLASS: 200°C
 TEMP. RISE: 130°C
 IMPEDANCE: 3.0 - 4.0%
 TAPS: FULL CURRENT
 BIL: 10 kV
 ENCLOSURE: TYPE 3R
 PRI AND SEC LUGS: Cu/Al 2-12 AWG
 APPROVALS: CSA, UL

OUTLINE DRAWING

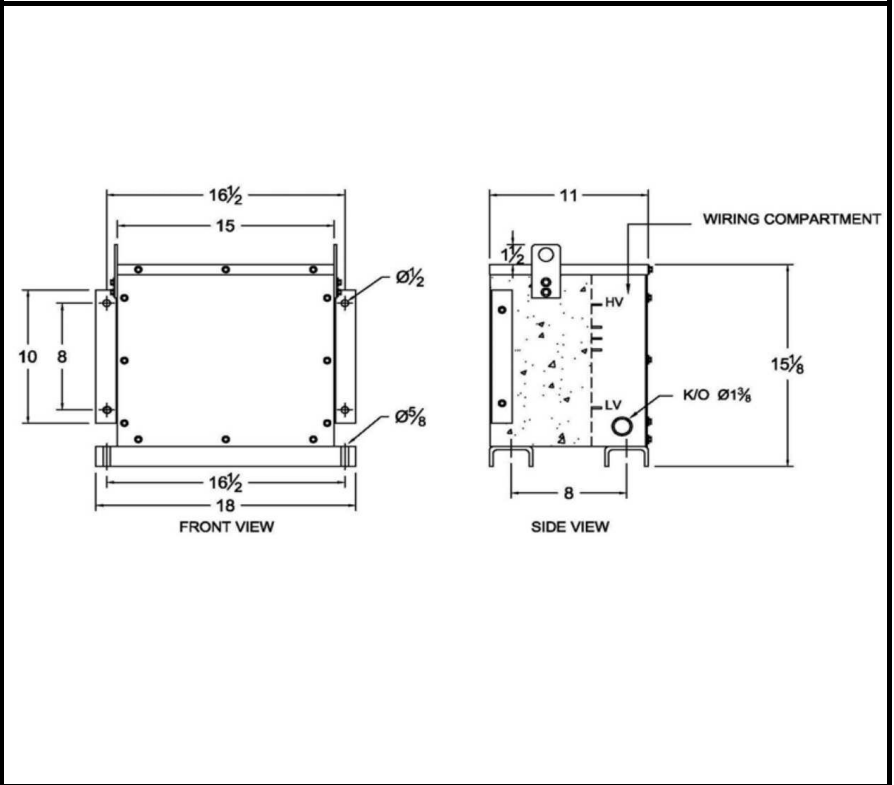

WIRING AND CONNECTION DIAGRAM

PRI VOLT	JUMPERS TO	PRI LINE CONN	SEC VOLT	PHASE	SEC LINE CONN
630	1-1-1	H1, H2, H3	400	3	X1, X2, X3
615	2-2-2	H1, H2, H3	230	1	BETWEEN X0 AND X1 or X2 or X3
600	3-3-3	H1, H2, H3			
585	4-4-4	H1, H2, H3			
570	5-5-5	H1, H2, H3			

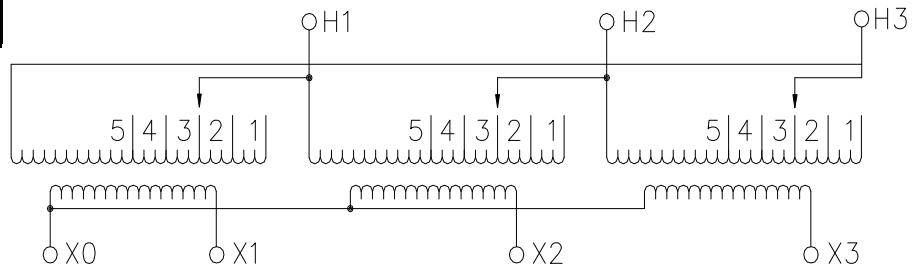

NOTE: Specifications and dimensions subject to change without notice