



**BEAVER ELECTRICAL MACHINERY**  
 7440 LOWLAND DRIVE, BURNABY, BC, CANADA  
 TEL: (604) 431-5000 FAX: (604) 431-5066  
 www.beaverelectrical.com

**TER SERIES  
 SPECIFICATION SHEET**

**3 PHASE TRANSFORMER  
 TYPE: EPOXY ENCAPSULATED  
 FLOOR OR WALL MOUNT**

CAT. NO.: TER15T-H34A  
 KVA: 15  
 PRIMARY VOLT: 600▲  
 SECONDARY VOLT: 208Y/120  
 PHASE: 3  
 FREQ: 60 HZ  
 WINDING MATL: Aluminum  
 WEIGHT: 370 LBS  
 INSUL. CLASS: 200°C  
 TEMP. RISE: 130°C  
 IMPEDANCE: 3.0 - 4.0%  
 TAPS: FULL CURRENT  
 BIL: 10 kV  
 ENCLOSURE: TYPE 3R  
 PRI AND SEC LUGS: Cu/Al 2-12 AWG  
 APPROVALS: CSA, UL

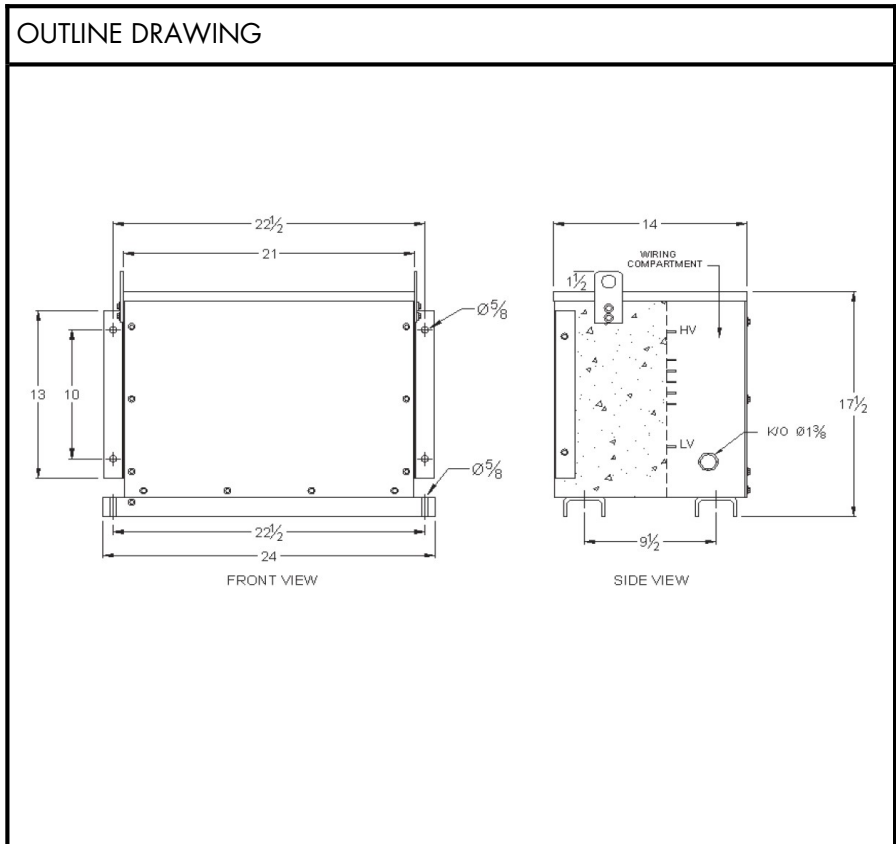

**WIRING AND CONNECTION DIAGRAM**

PRI VOLT	JUMPERS TO	PRI LINE CONN	SEC VOLT	PHASE	SEC LINE CONN
630	1-1-1	H1, H2, H3	208	3	X1, X2, X3
615	2-2-2	H1, H2, H3	120	1	BETWEEN X0 AND X1 or X2 or X3
600	3-3-3	H1, H2, H3			
585	4-4-4	H1, H2, H3			
570	5-5-5	H1, H2, H3			

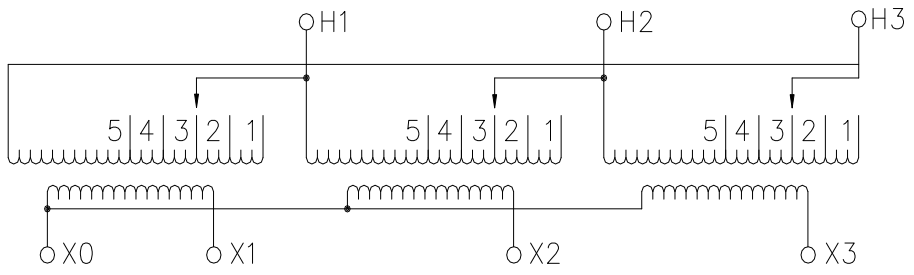

NOTE: Specifications and dimensions subject to change without notice