



Technical Documentation

APH0206-841

Advantage Plus IEEE 841 | AEHH8B

Beaver Electrical Machinery Ltd.

Date: July 25, 2022



Dimensional Drawing

Catalogue	Type	HP	RPM	Voltage	Hz	Frame Size
APH0206-841	AEHH8B	20	1200	460	60	286T

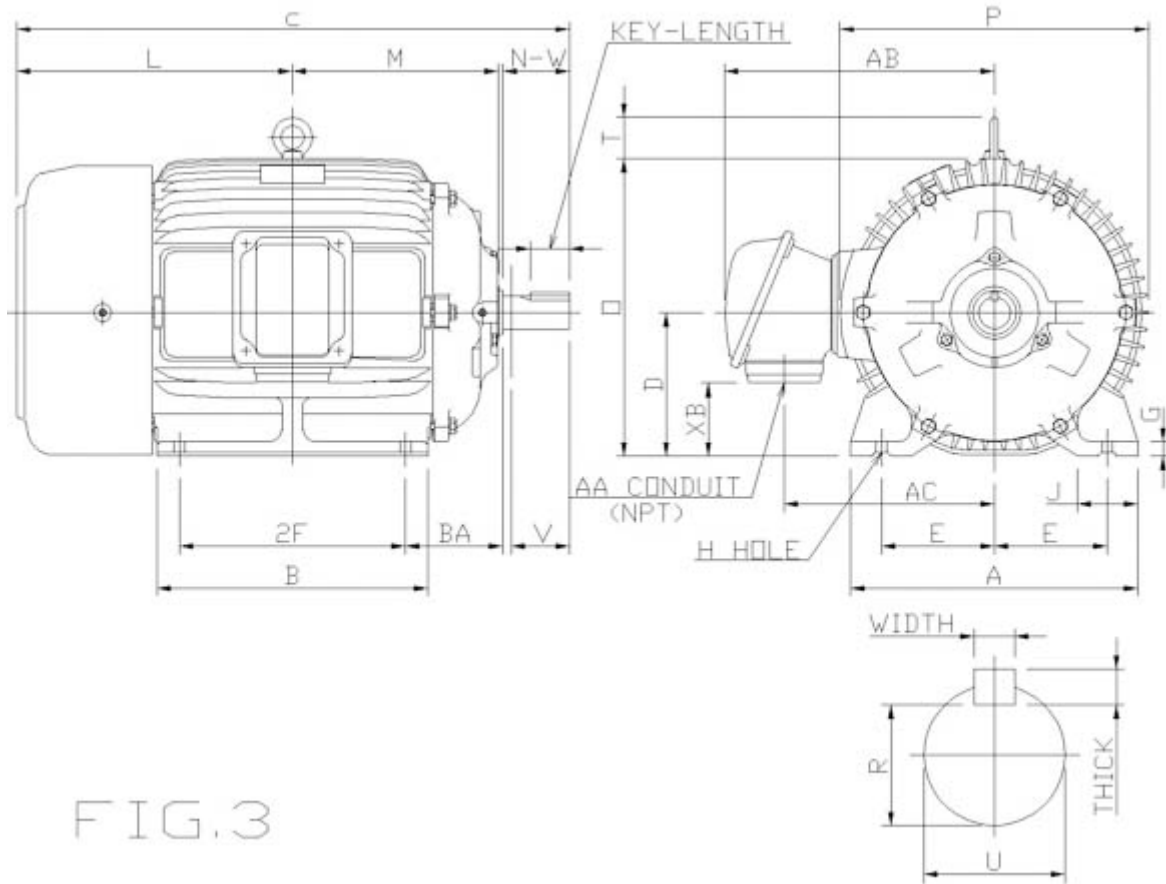

FIG.3



Mounting					A	B	C	CL1	CL2	D	G
E	2F1	2F2	H	BA							
5.5	11	9.5	0.53	4.75	13.98	13.19	28.3			7	0.7

J	K	L	M	O	P	T
2.95		13.43	9.98	14.5	15.05	2.36

Terminal Housing			
AA	AB	AC	XB
NPT11/2"	13.27	10.35	3.54

Shaft Extension			Key			Keyseat
N-W	U	V	Width	Thick	Length	R
4.62	1.875	4.5	0.5	0.5	3.28	1.591

Bearings		Weight Lbs	Drive Method	Dimensions
DE	NDE			
6311ZC3	6310ZC3	510	Direct Coupling / Belt Drive	Inches

	Beaver Electrical Machinery Ltd.	
	Date: July 25, 2022	

Technical Data Sheet

Motor Type: AEHH8B	Catalogue No: APH0206-841
--------------------	---------------------------

Nameplate Information

HP	Pole	RPM	Frame	Voltage	Hz	Phase
20	6	1170	286T	460	60	3
Enclosure	Ins. Class	Service Factor	Time Rating	NEMA Design	Rated Amb.	Rated Altitude
TEFC	F	1.15	Continuous	B	-40 to 40 °C	<1000 m

Typical Performance

Efficiency (%)				Power Factor (%)		
Full Load		3/4 Load	1/2 Load	Full Load	3/4 Load	1/2 Load
Nom.	Min.					
91.7	90.2	92.4	92.4	84	81	73
Torque				Current (A)		
Full Load (lb-ft)	Locked Rotor (% FLT)	Pull Up (% FLT)	Break Down (% FLT)	No Load	Full Load	Locked Rotor
89.75	210	160	225	7.5	24.3	145
NEMA KVA Code	Inertia (WR ²)			Safe Stall Time (s)		Noise Level Sound Press. dB(A)
	Rotor (lb-ft ²)	NEMA Load (lb-ft ²)	Max. Allowable (lb-ft ²)	Cold	Hot	
G	8.34	262	610	35	25	66

VFD Duty Information

Max HP	Current (A)	Speed Range		VFD		S.F.
		Constant Torque	Variable Torque	Carrier Hz	Type	
20	24.31	6-60Hz	3-60Hz	3-6kHz	VPWM or CPWM	1

Hazardous Locations Information



CSA Certified
Class I, Div 2, Groups B, C & D Class I, Zone 2, Groups IIB+H2, IIB & IIA
Temp Code (Sinewave / VFD) T3C / T3B

Additional Certifications

Other Certification

Additional Information

Bearings		Approx. Weight
DE	NDE	lbs
6311ZC3	6310ZC3	510

	Beaver Electrical Machinery Ltd.	
	Date: July 25, 2022	

Nameplate Drawing

Advantage Plus IEEE 841					
TYPE	AEHH8B		CAT. NO.	APH0206-841	
OUTPUT	20 HP 14.92 kW		FRAME	286T	TEFC
R.P.M.	1170		POLE	6	INS. F
VOLTS	460		PHASE	3	Hz 60
AMPS	24.3		CODE	G	S.F. 1.15
AMBIENT	40 °C		NOM. EFF. 91.7		MIN. EFF. 90.2
BEARINGS	6311ZC3 / 6310ZC3				RATING Cont.
SER. NO.	TBD		DESIGN	B	WT. 510 LBS
PWM VFD DUTY	VT	CT	CP		S.F.
	3-60Hz	6-60Hz	60-120Hz		1



Connection Diagram

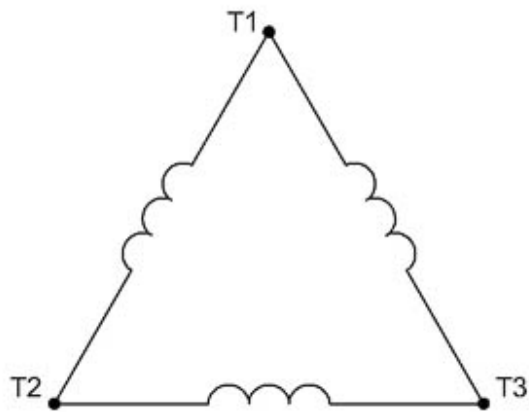

3 LEAD SINGLE VOLTAGE DELTA					
VOLTAGE	CONN.	L1	L2	L3	
-	DELTA	1	2	3	

WD_3D



Thermal Limit Curves

Motor Type: AEHH8B		Catalogue No: APH0206-841		Family: Advantage Plus IEEE 841	
HP	20	Safe Stall Time		Full Load A	24.3 A
Voltage	460V 60Hz	Hot	25 s	% Inrush	596 %
RPM	1200	Cold	35 s	Locked Rotor A	145 A

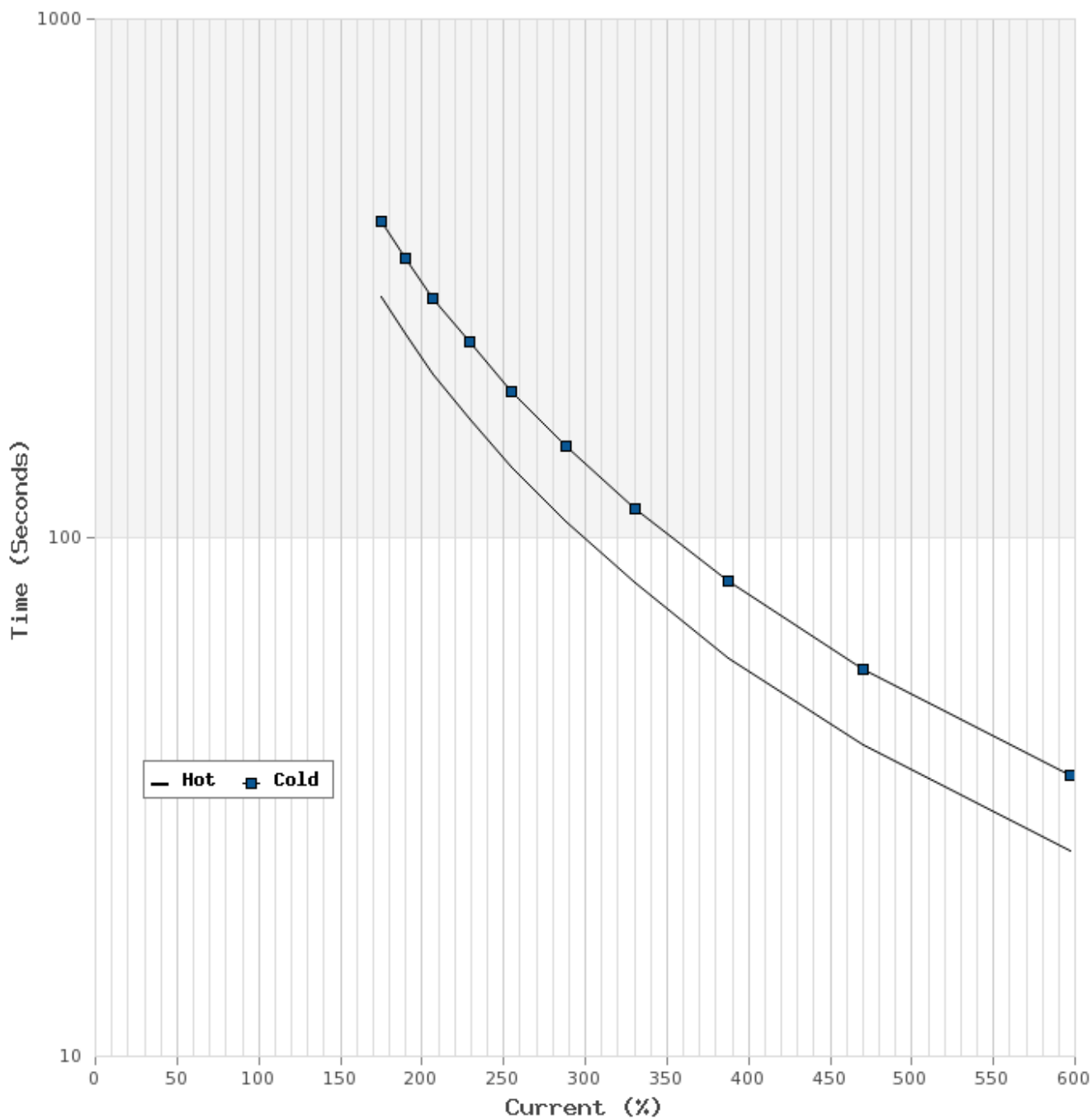



T-N and I-N Curves

Motor Type: AEHH8B		Catalogue No: APH0206-841		Family: Advantage Plus IEEE 841	
HP	20	Full Load T	89.75 lb-ft	Full Load A	24.3 A
Voltage	460V 60Hz	Locked Rotor T	210 %	Locked Rotor A	145.0 A
RPM	1200	Pull Up T	160 %	Break Down T	225 %

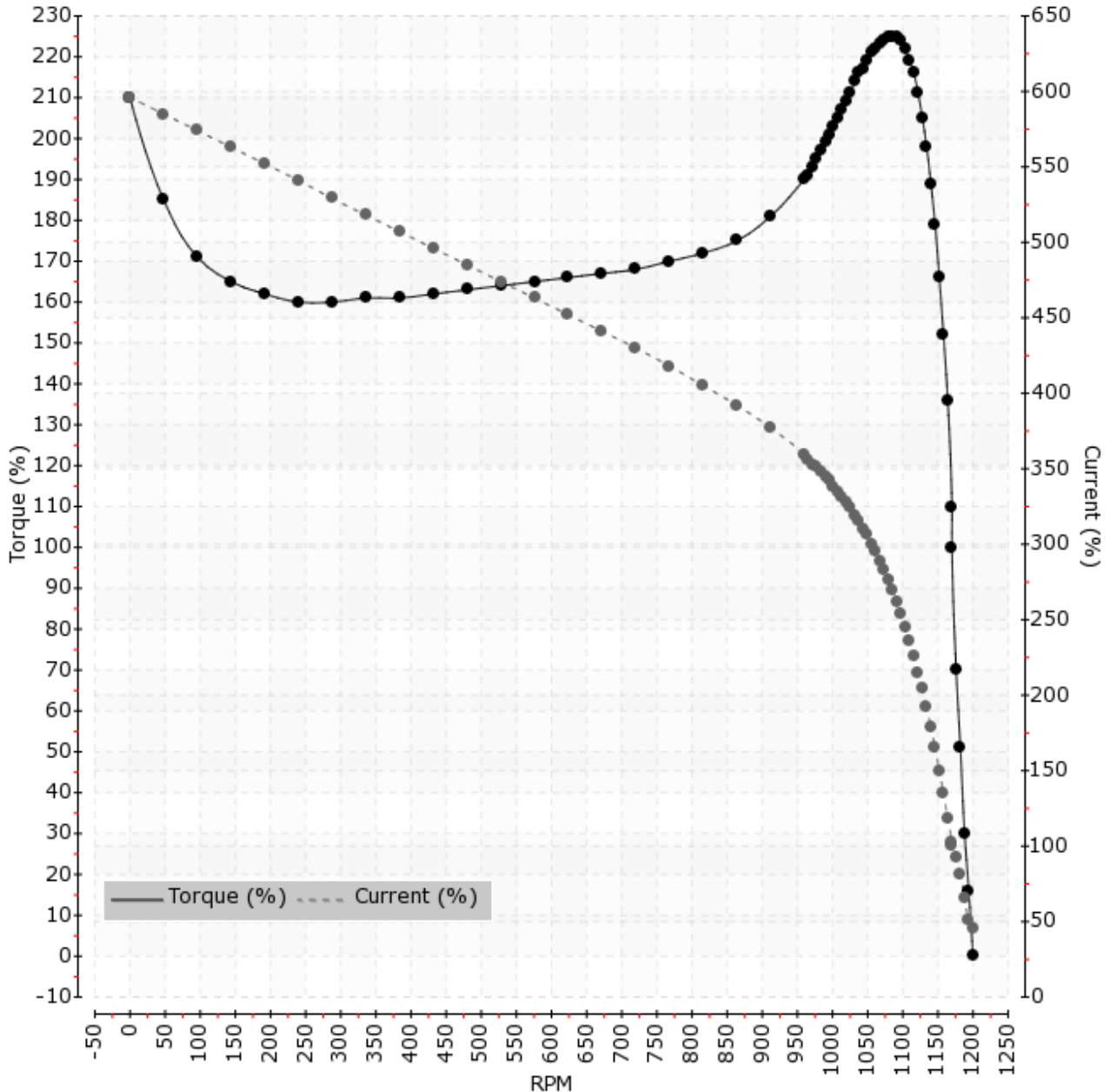



Dimensional Drawing (50 Hz)

Catalogue	Model	HP	Pole	kW	Rating	Voltage	Hz	RPM
APH0206-841	AEHH8B	20	6	14.92	Continuous	380	50	

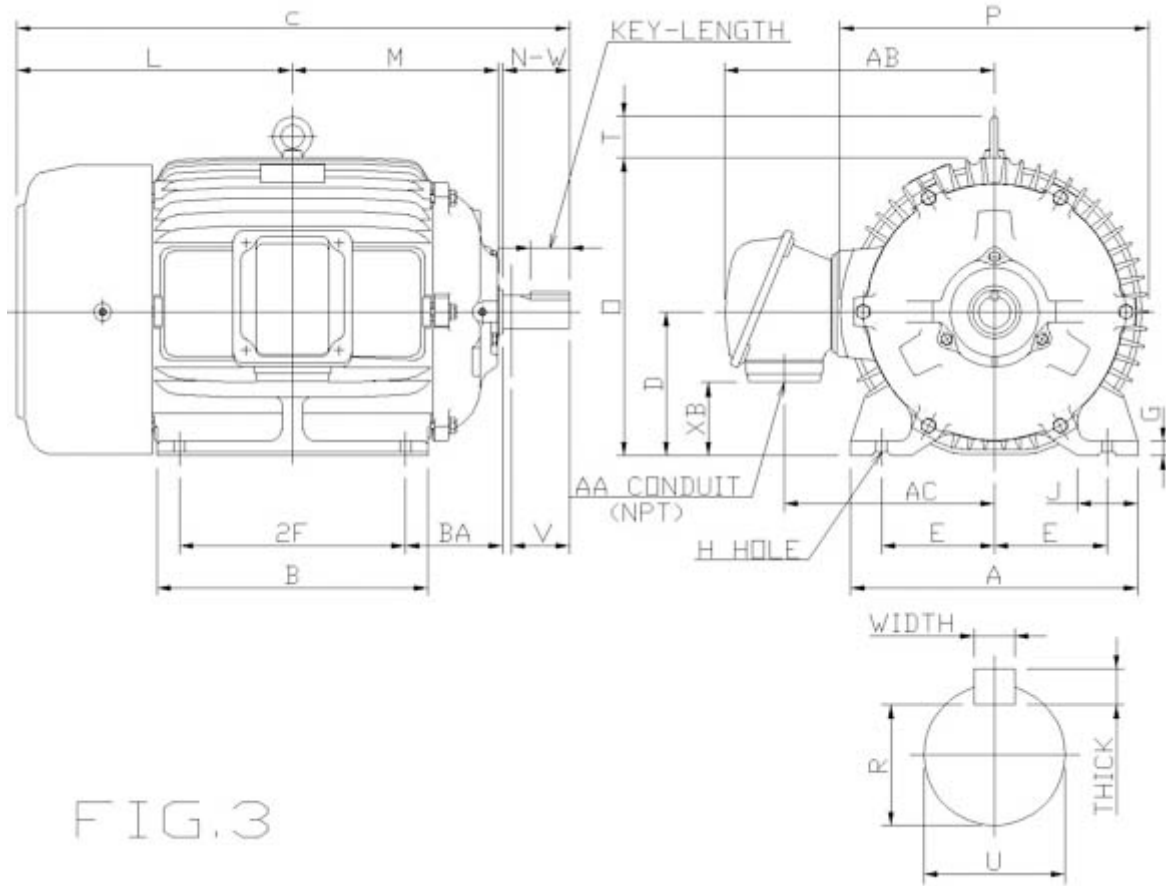



FIG. 3

Frame Size	Mounting					A	B	C	CD	D	
	E	2F	2F2	H	BA						
286T	5.5		9.5	0.53	4.75	13.98	13.19	28.3		7	
G	J	K	L	M	O	P	T	Key			Keyseat R
								Width	Thick	Length	
0.7	2.95		13.43	9.98	14.5	15.05	2.36	0.5	0.5	3.28	1.591
Terminal Housing				Aux Box		C/D Flange					
AA	AB	AC	XB	AE	AX	BB	AH	AK	BD	AJ	BF
NPT11/2"	13.27	10.35	3.54								
Shaft Extension			Bearings		Approx. Weight Lbs	SPL dBA/3ft	Ins. Class	S.F.	Drive Method	Dimensions	
N-W	U	V	DE	NDE							
4.62	1.875	4.5	6311ZC3	6310ZC3	510	66	F	1	Direct Coupling / Belt Drive	Inches	

	Beaver Electrical Machinery Ltd.	
	Date: July 25, 2022	

Technical Data Sheet (50 Hz)

Motor Type: AEHH8B	Catalogue No: APH0206-841
--------------------	---------------------------

Nameplate Information

HP	Pole	RPM	Frame	Voltage	Hz	Phase
20	6		286T	380	50	3
Enclosure	Ins. Class	Service Factor	Time Rating	NEMA Design	Rated Amb.	Rated Altitude
TEFC	F	1	Continuous	B	-40 to 40 °C	<1000 m

Typical Performance

Efficiency (%)				Power Factor (%)		
Full Load		3/4 Load	1/2 Load	Full Load	3/4 Load	1/2 Load
Nom.	Min.					
89.7	87.7	91.7	93	85	84.50	79.50
Torque				Current (A)		
Full Load (lb-ft)	Locked Rotor (% FLT)	Pull Up (% FLT)	Break Down (% FLT)	No Load	Full Load	Locked Rotor
109	155	120	200	7.1	29.7	194
NEMA KVA Code	Inertia (WR ²)			Safe Stall Time (s)		Noise Level Sound Press. dB(A)
	Rotor (lb-ft ²)	NEMA Load (lb-ft ²)	Max. Allowable (lb-ft ²)	Cold	Hot	
H	8.34	407.1	771.43	27	19	66

VFD Duty Information

Speed Range			VFD		S.F.
Constant Torque	Variable Torque	Constant Power	Carrier	Type	
6-50Hz	3-50Hz	50-100Hz	3-6kHz	VPWM or CPWM	1

Hazardous Locations Information

CSA Certified
Class I, Div 2, Groups B, C & D Class I, Zone 2, Groups IIB+H2, IIB & IIA
Temp Code (Sinewave / VFD) T3C / T3B

Additional Certification

Other Certification

Additional Information

Bearings		Approx. Weight
DE	NDE	lbs
6311ZC3	6310ZC3	510