



# MARCUS

Marcus Transformer LTD  
 Phone: 1-800-267-7376  
 Fax: 1-866-205-7526  
 Email: Info@marcustransformer.com

## TECHNICAL DATA MODEL: MTH 45A1

3-PHASE ISOLATING EFFICIENT TRANSFORMER

DESCRIPTION	
Type	DRY TYPE DISTRIBUTION (ANN)
KVA	45
Primary (Volts)	600
Secondary (Volts)	208Y / 120
Phase	3
Enclosure	NEMA 1
Impedance (%z)	3.7
Insulation Class	220°C
Temperature Rise	150°C
Frequency	60Hz
Weight (LBS/KG)	475 / 215
Connection	Dyn1(TT-1)
BIL.	10KV

Primary connectors per phase :	#14-#4
Secondary connectors per phase:	#6-250MCM

### FEATURES:

- Anti-vibration pads installed between the core/coil and the enclosure
- Ground lug provided
- Leads brought-up and solidly positioned into separate terminal boards
- CSA enclosure: ventilated painted ASA 61gray
- Transformer meets the premium efficiency values as per NRCAN2019 / DOE 2016
- Copper ground strap between core/coil and enclosure
- CSA certified / UL listed
- Copper windings

PERFORMANCE (at 100% load)	
No load loss	120W
Total loss	1420W
Noise level	45dB

EFFICIENCY	
	Efficiency = 98.40% (As per NRCAN 2019 and DOE 2016)

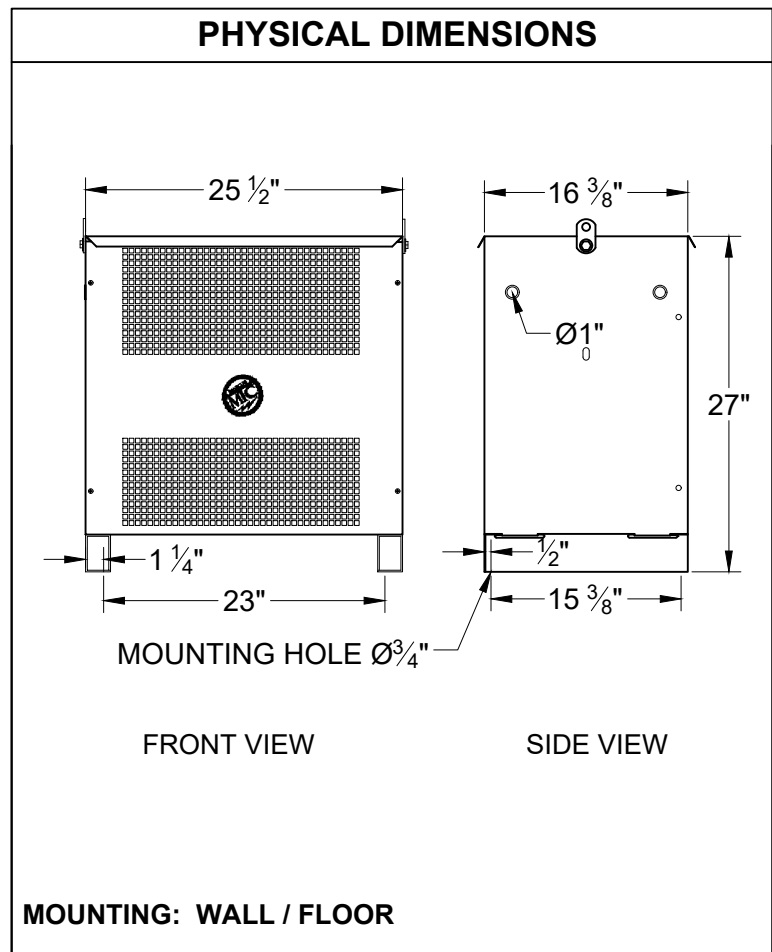

Customer / PO	
Project	
Engineer	
Contractor	
Revision Date	

COMMENTS